

SECTION A-A  
SCALE 1 : 2.5

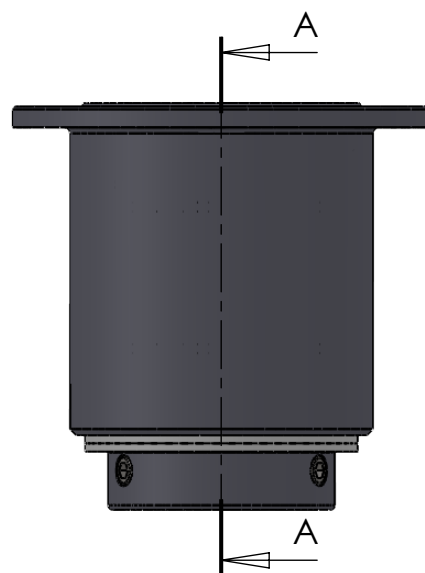

| ITEM NO. | PART NUMBER  | PART NAME                                                                     | QTY. |
|----------|--------------|-------------------------------------------------------------------------------|------|
| 1        | DIN916-10x10 | Socket set Screw M10x10mm                                                     | 3    |
| 2        | M01-272      | Roller $\varnothing 12.5 \times 44\text{mm}$                                  | 18   |
| 3        | M03-207      | Delrin Lockring $\varnothing 88,5 \times \varnothing 71 \times 1,75\text{mm}$ | 2    |
| 4        | M03-615      | Delrin Lockring $\varnothing 90 \times \varnothing 75,7 \times 2,75\text{mm}$ | 1    |
| 5        | M03-620      | Delrin Lockring $\varnothing 90 \times \varnothing 71 \times 2,75$            | 1    |
| 6        | M05-158      | L-ring $\varnothing 60 \varnothing 63.5 \varnothing 85$                       | 2    |
| 7        | M36-050      | Outer house 42050Z                                                            | 1    |
| 8        | M39-060      | Hanger $\varnothing 60$                                                       | 1    |
| 9        | M41-510      | 5mm delrin ball                                                               | 50   |
| 10       | M43-088      | Cover with M88                                                                | 1    |
| 11       | O-ring       | Rubber ring $\varnothing 80 \times 2.5$                                       | 1    |

DWG NR / NAME:

42060Z / Top roller Bearing

BATCH NR:

PROJECT:

Shaft  $\varnothing 60\text{mm}$ . Max working load 3000kg

REKV.NR / ORDRE NR:

DATE:

06-12-2010

NAME:

JR

SCALE / PAPER:

1:3 / A4

MATERIAL:

WEIGHT:

g

LOCATION:

REV:

ORDRE DATO:

LEV.DATO:

MODIFY DATE:

: /

*Jefa Rudder*  
SYSTEMS

JEFA MARINE A/S  
NIMBUSVEJ 2  
2670 GREVE, DENMARK

Tlf: +45 4615 5210 & Fax: +45 46155208  
Email: info@jefa.com www.jefa.com