

ITEM NO.	Part name	QTY.
1	BS25-11 BS25 bulkhead steerer with 11 teeth 5/8"	1
2	BS25-SUP Support bearing for BS25 bulkhead steerer	1
3	WHS1200L Standard wheel 1200 mm with leather cover	1
4	TERM-A-1D Articulated terminal unit with 100 mm delrin sheaves	1
5	QU2580 80° quadrant R=250, maximum bore size = 100 mm.	1
6	QUBORE bore ø50 and 10mm key 0°	1
7	QUAUTO surcharge for additional autopilot arm connected to quadrant	1
8	QUEXTEND Extension of quadrant tracks from boss, 120mm.	
9	IPW100D Parallel wire idler with 100 mm delrin sheaves	1
10	CONBRA100 Bracket for conduit fit / 100mm sheave	2
11	CONFIT Brass conduit fitting	2
12	CONCAB 16 mm heavy duty conduit cable	1
13	CH5860 Chain assembly 5/8", 600 mm long	1
14	W5-300 Steering wire 5 mm diameter 3000 mm long	2
15	Nordship 46DS rudderstock ø108mm	1
16	RUD46 Rudderblade 1,1m2	1
17	4S050Z Top self-aligning roller bearings with deck cover	1
18	6T0108 Self-aligning PETP lower roller bearings type 6T	1
19	GA180095 Gaiter	1

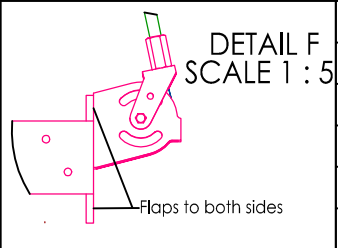
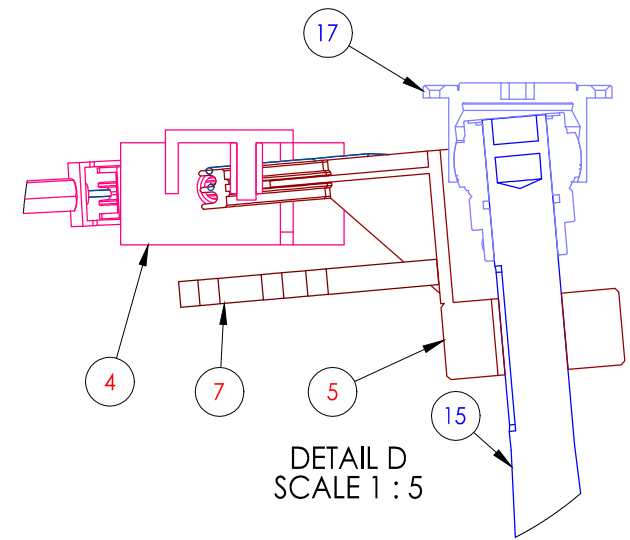
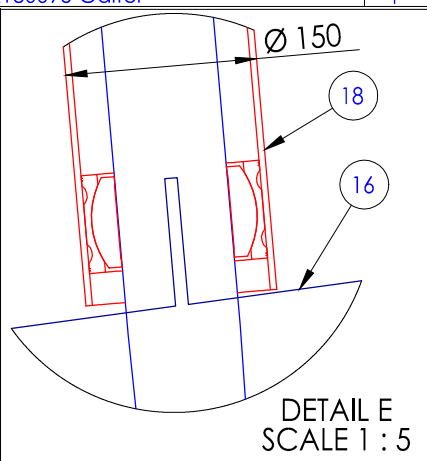
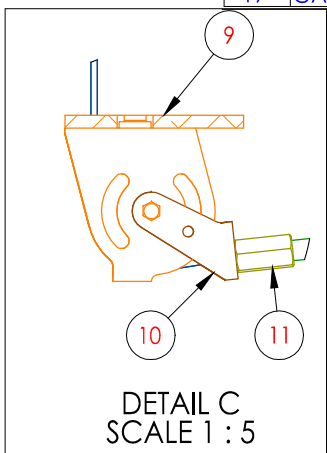
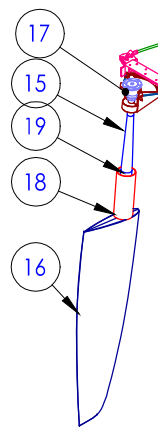
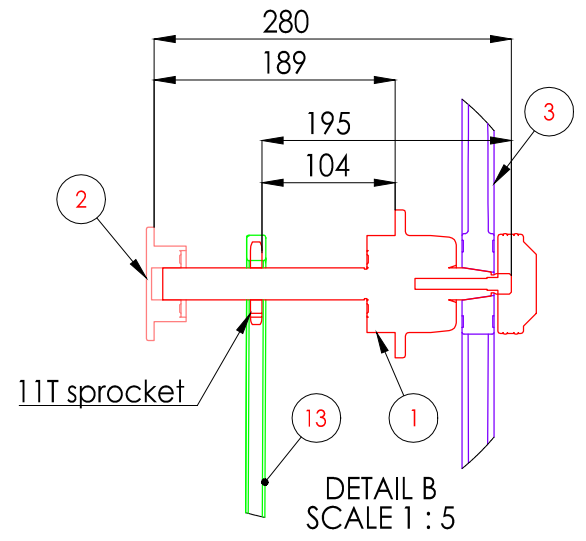

Modify date	Project: Nordship 46DS Steering system	
Modify date	Scale —	Date 12/03-2012
Modify date	Material —	Drawing no. Steering system
Modify date	Filename Nordship 46DS buildcard (dwg)	
Modify date	Drawn by KJ	

Jefa Steering
 SYSTEMS
 Jefa STEERING ApS
 AGENAVEJ 43
 2670 GREVE, DENMARK
 Tlf.+45 46155210 & Fax +45 43695211
 E-mail: info@jefa.com www.jefa.com