

SECTION A-A

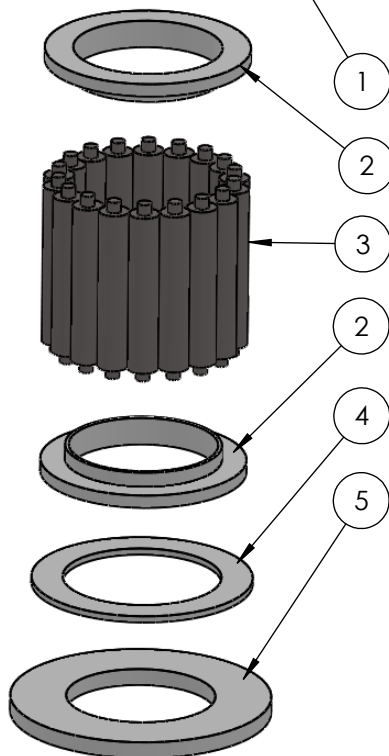
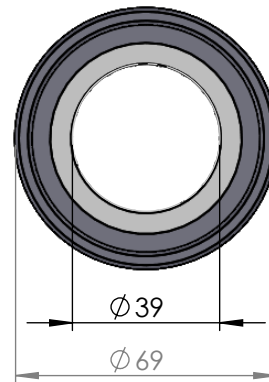
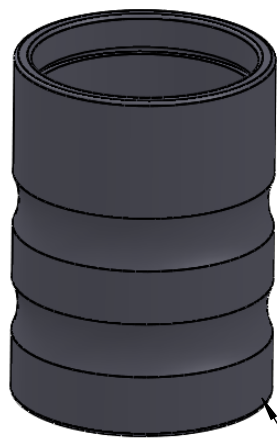
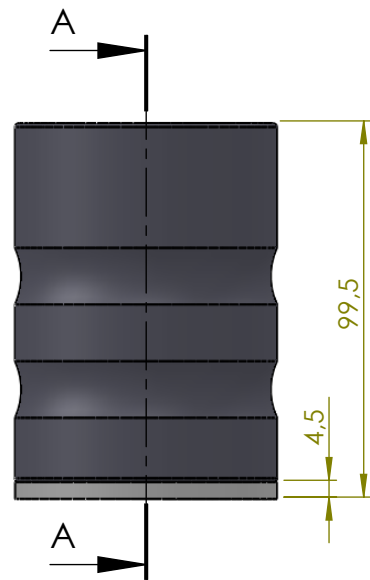

ITEM NO.	PART NUMBER	PART NAME	EXPL /QTY
1	M21-101	Bearing House 41030-41039	1
2	M05-104	L-ring ø39 ø41.5 ø55	2
3	M01-201	Roller ø8 x 44mm	18
4	M03-189	Delrin Lockring ø58,5 x ø42 x 1,75mm	1
5	M07-104	Washer ø39.5 x ø69	1

DWG NR / NAME:

41039 / Lower roller bearing

BATCH NR:

PROJECT:

Shaft Ø39mm, max working load 2000kg

REKV.NR / ORDRE NR:

DATE:

04-06-2009

NAME:

JR

SCALE / PAPER:

1:2 / A4

MATERIAL:

WEIGHT:

g

LOCATION:

ORDRE DATO:

MODIFY DATE:

: /

REV:

LEV.DATO:

Jefa Rudder
SYSTEMS

JEFA MARINE A/S
NIMBUSVEJ 2
2670 GREVE, DENMARK

Tlf: +45 4615 5210 & Fax: +45 4615208
Email: info@jefa.com www.jefa.com