

SECTION A-A

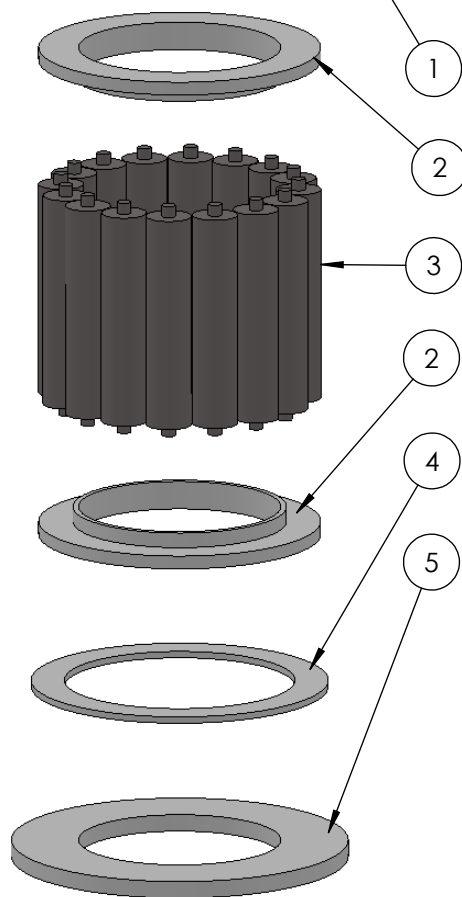
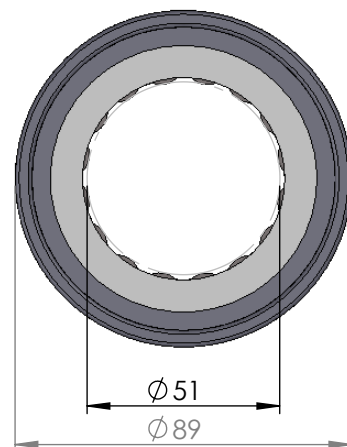
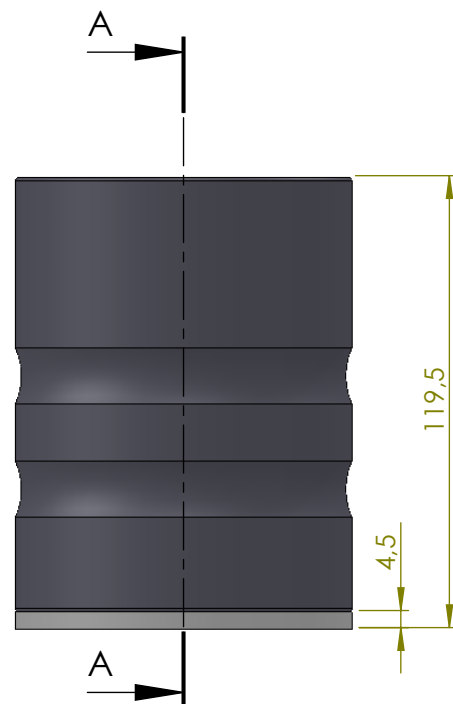

ITEM NO.	PART NUMBER	PART NAME	EXPL /QTY
1	M21-105	Rollerbearing $\phi 50 - \phi 59$ mm	1
2	M05-137	L-ring $\phi 53 \times \phi 56.5 \phi 75$	2
3	M01-364	Roller $\phi 12.0 \times 57$ mm	16
4	M03-201	Delrin Lockring $\phi 78,5 \times \phi 61 \times 1,75$ mm	1
5	M07-119	Washer $\phi 53.5 \phi 89$	1

DWG NR / NAME:

41051 / Lower roller bearing

BATCH NR:

PROJECT:

Shaft $\phi 51$ mm, Max working load 3900kg

REKV.NR / ORDRE NR:

DATE:

09-06-2009

NAME:

JR

SCALE / PAPER:

1:2 / A4

MATERIAL:

WEIGHT:

g

LOCATION:

ORDRE DATO:

MODIFY DATE:

: /

REV:

LEV.DATO:

Jefa Rudder
SYSTEMS

JEFA MARINE A/S
NIMBUSVEJ 2
2670 GREVE, DENMARK

Tlf: +45 4615 5210 & Fax: +45 4615208
Email: info@jefa.com www.jefa.com