

SECTION A-A

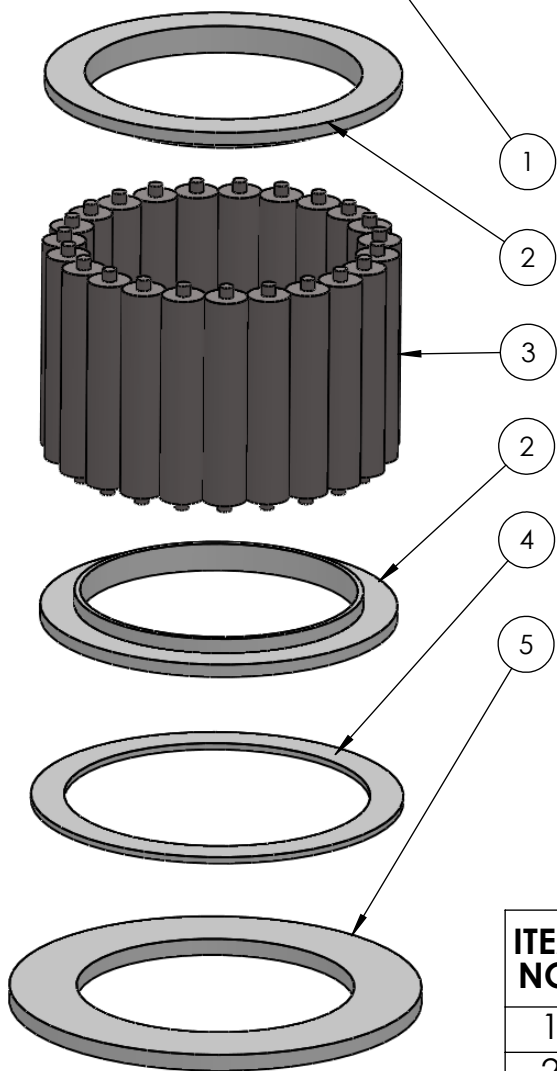

| ITEM NO. | PART NUMBER | PART NAME                                                                     | EXPL /QTY |
|----------|-------------|-------------------------------------------------------------------------------|-----------|
| 1        | M21-109     | Rollerbearing $\varnothing 70 - \varnothing 79\text{mm}$                      | 1         |
| 2        | M05-179     | L-ring $\varnothing 73 \varnothing 76.5 \varnothing 95$                       | 2         |
| 3        | M01-356     | Roller $\varnothing 11.5 \times 57\text{mm}$                                  | 23        |
| 4        | M03-213     | Delrin Lockring $\varnothing 98,5 \times \varnothing 81 \times 1,75\text{mm}$ | 1         |
| 5        | M07-149     | Washer $\varnothing 73.5 \varnothing 109$                                     | 1         |

DWG NR / NAME:

**41072 / Lower roller bearing**

BATCH NR:

PROJECT:

Shaft  $\varnothing 72\text{mm}$ , max working load 5100kg

REKV.NR / ORDRE NR:

DATE:

10-06-2009

NAME:

JR

SCALE / PAPER:

1:2 / A4

MATERIAL:

WEIGHT:

g

LOCATION:

REV:

ORDRE DATO:

LEV.DATO:

*Jefa Rudder*  
SYSTEMS

JEFA MARINE A/S  
NIMBUSVEJ 2  
2670 GREVE, DENMARK

Tlf: +45 4615 5210 & Fax: +45 4615208  
Email: info@jefa.com www.jefa.com

MODIFY DATE:

: /