

SECTION A-A

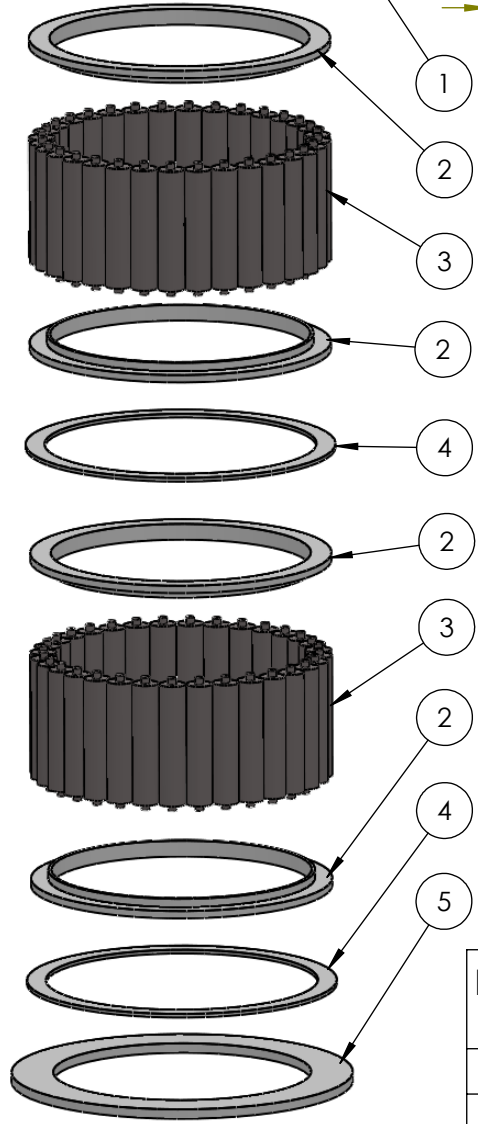
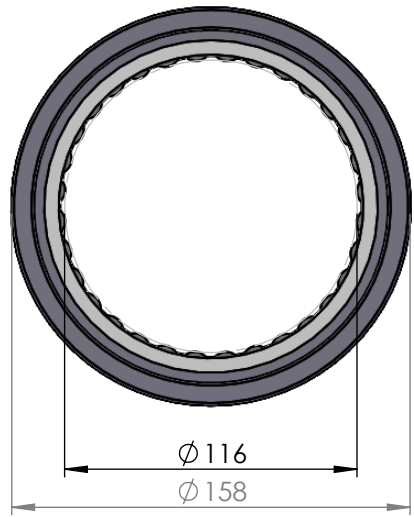

ITEM NO.	PART NUMBER	PART NAME	EXPL /QTY
1	M21-119	Rollerbearing $\phi 115 - \phi 124$ mm	1
2	M05-290	L-ring $\phi 120 \phi 123.5 \phi 140$	4
3	M01-364	Roller $\phi 12.0 \times 57$ mm	64
4	M03-280	Delrin Lockring $\phi 143,5 \times \phi 126 \times 1,75$ mm	2
5	M07-206	Washer $\phi 119.5 \phi 158$	1

DWG NR / NAME:

41116 / Lower roller bearing

BATCH NR:

PROJECT:
Shaft $\phi 116$ mm, max working load 15300kg

REKV.NR / ORDRE NR:

DATE:
23-06-2009
MODIFY DATE:

NAME:
JR

SCALE / PAPER:
1:3 / A4

MATERIAL:
WEIGHT: g

LOCATION:
REV:

ORDRE DATO:
LEV.DATO:

Jefa Rudder
SYSTEMS
JEFA MARINE A/S
NIMBUSVEJ 2
2670 GREVE, DENMARK
Tlf: +45 4615 5210 & Fax: +45 46155208
Email: info@jefa.com www.jefa.com

: /