

SECTION A-A
SCALE 1 : 1.5

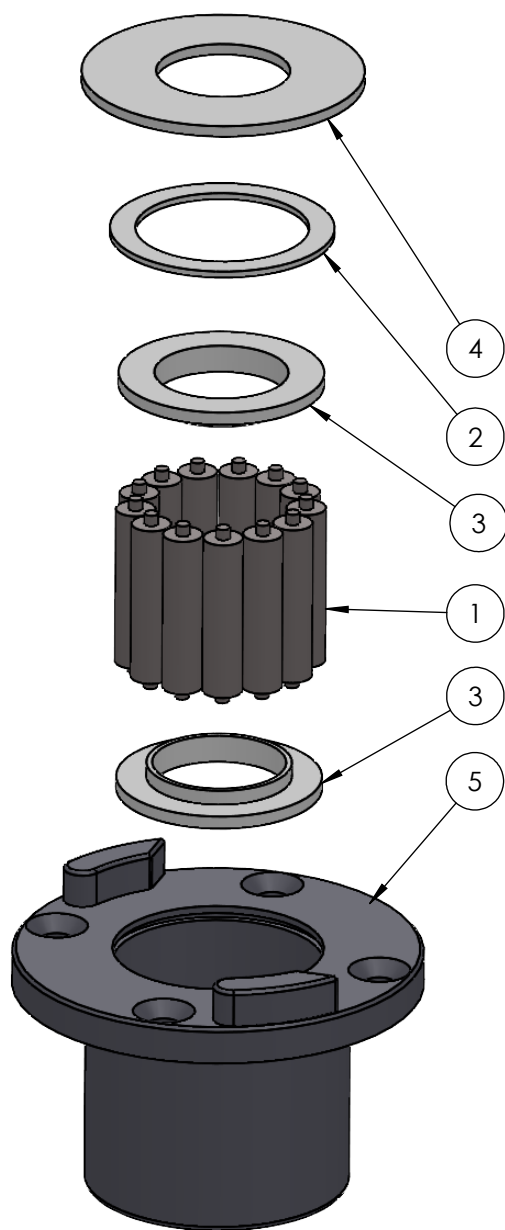
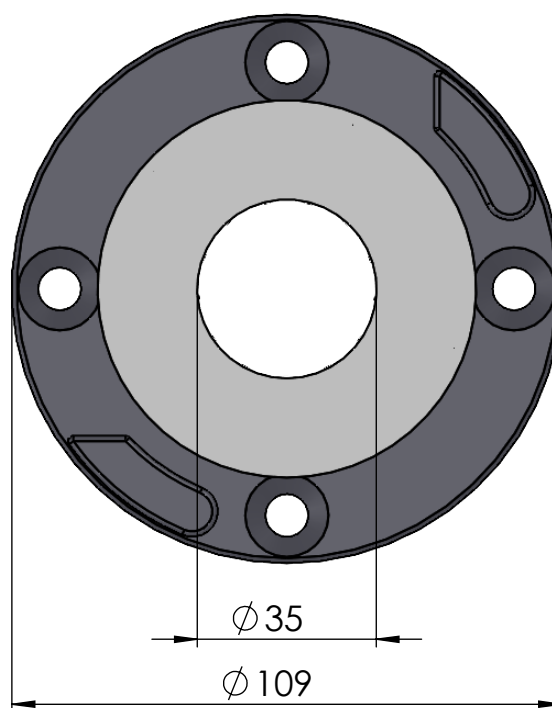
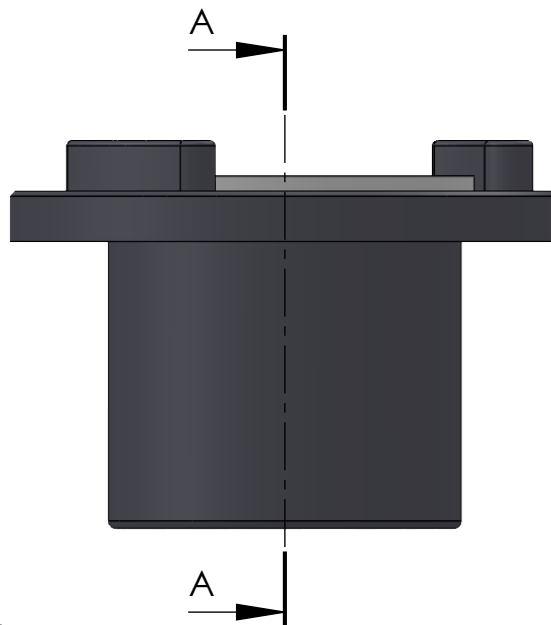

ITEM NO.	PART NUMBER	PART NAME	QTY
1	M01-240	Roller $\phi 10.5 \times 44\text{mm}$	13
2	M03-191	Delrin Lockring $\phi 59,5 \times \phi 46 \times 1,75\text{mm}$	1
3	M05-101	L-ring $\phi 35 \times \phi 55$	2
4	M07-101	Washer, delrin $\phi 35,5 \times \phi 75 \times 3\text{mm}$	1
5	M23-105	Top roller bearing house with stop	1

DWG NR / NAME:

42035STP / Top roller bearing with stop

BATCH NR:

PROJECT:

Shaft $\phi 35\text{mm}$, Max working load 2000kg

REKV.NR / ORDRE NR:

DATE:

13-11-2009

NAME:

JR

SCALE / PAPER:

1:2 / A4

MATERIAL:

WEIGHT:

g

LOCATION:

REV:

ORDRE DATO:

LEV.DATO:

MODIFY DATE:

: /

Jefa Rudder
SYSTEMS

JEFA MARINE A/S
NIMBUSVEJ 2
2670 GREVE, DENMARK

Tlf: +45 4615 5210 & Fax: +45 4615208
Email: info@jefa.com www.jefa.com