

SECTION A-A
SCALE 1 : 1.75

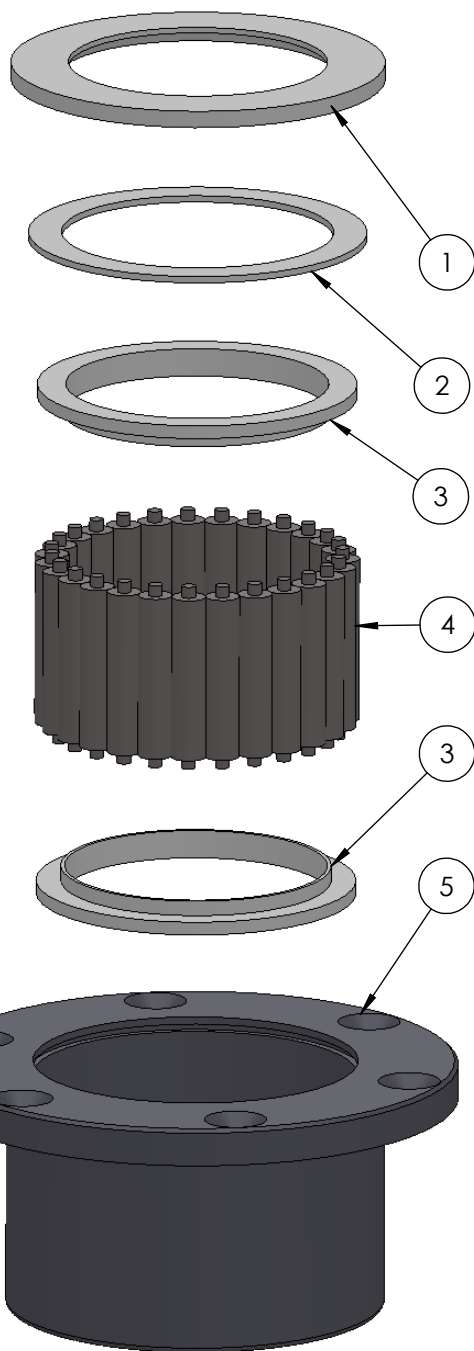
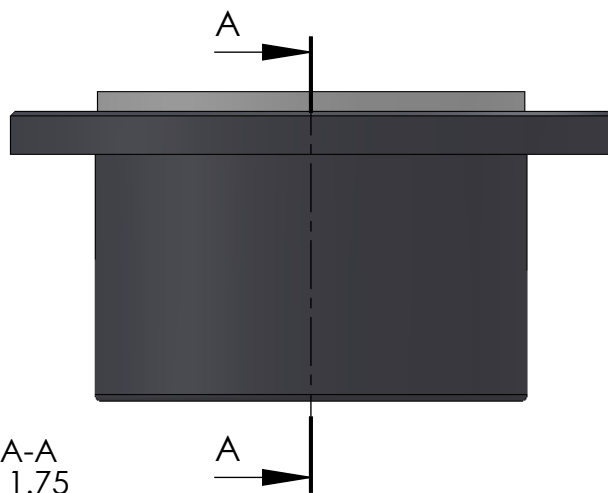

ITEM NO.	PART NUMBER	PART NAME	EXPL /QTY
1	M07-142	Washer $\phi 68.5$ $\phi 99$	1
2	M03-209	Delrin Lockring $\phi 89,5$ x $\phi 72$ x 1,75mm	1
3	M05-170	L-ring $\phi 69$ $\phi 71.5$ $\phi 85$	2
4	M01-216	Roller $\phi 9$ x 44mm	27
5	M23-130	Top roller bearing $\phi 60$ - $\phi 70$	1

DWG NR / NAME:

42068 / Top roller bearing

BATCH NR:

PROJECT:

Shaft $\phi 68$ mm, Max working load 4500kg

REKV.NR / ORDRE NR:

DATE:

27-05-2009

NAME:

JR

SCALE / PAPER:

1:2 / A4

MATERIAL:

WEIGHT:

g

LOCATION:

REV:

ORDRE DATO:

LEV.DATO:

MODIFY DATE:

: /

Jefa Rudder
SYSTEMS

JEFA MARINE A/S
NIMBUSVEJ 2
2670 GREVE, DENMARK

Tlf: +45 4615 5210 & Fax: +45 4615208
Email: info@jefa.com www.jefa.com