

SECTION A-A
SCALE 1 : 4

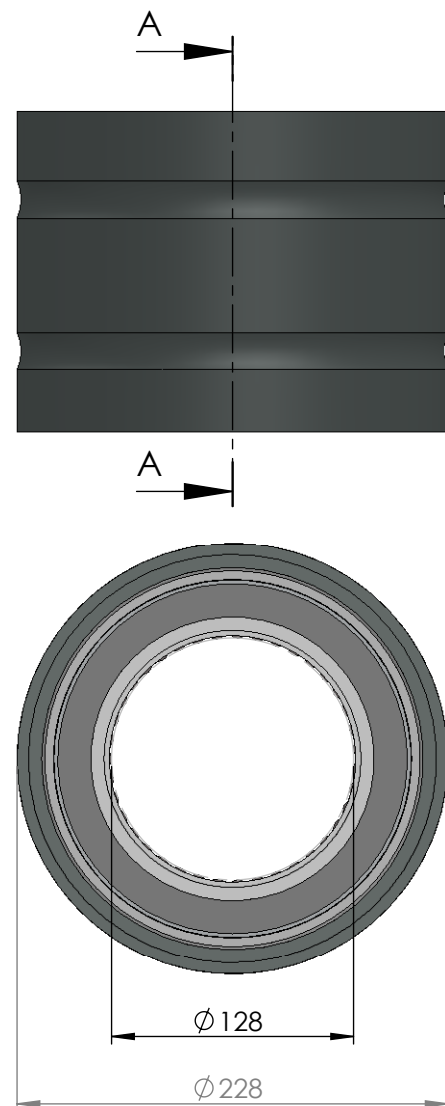

ITEM NO.	PART NUMBER	PART NAME	QTY.
1	M01-348	Roller $\varnothing 11.0 \times 57\text{mm}$	78
2	M03-290	Lockring $\varnothing 136 \varnothing 154$	3
3	M05-314	L-ring $\varnothing 130 \varnothing 133.5 \varnothing 150$	4
4	M07-239	Washer $\varnothing 170.5 \varnothing 219$	1
5	M09-125	Alu lockring $\varnothing 180.5 \times \varnothing 189.5$	1
6	M15-140	Ball for 43125-43160	1
7	M25-120	Yderhus for 43125-43154	1
8	M27-150	Inderhus for 43125-43134	1

DWG NR / NAME:

43128 / Self-aligning roller bearing

BATCH NR:

PROJECT:

Shaft $\varnothing 128$ max working load 16600kg

REKV.NR / ORDRE NR:

DATE:

17-12-2009

NAME:

JR

SCALE / PAPER:

1:5 / A4

MATERIAL:

WEIGHT:

g

LOCATION:

REV:

ORDRE DATO:

LEV.DATO:

MODIFY DATE:

: /

Jefa Rudder
SYSTEMS

JEFA MARINE A/S
NIMBUSVEJ 2
2670 GREVE, DENMARK

Tlf: +45 4615 5210 & Fax: +45 4615208
Email: info@jefa.com www.jefa.com