

SECTION A-A
SCALE 1 : 4

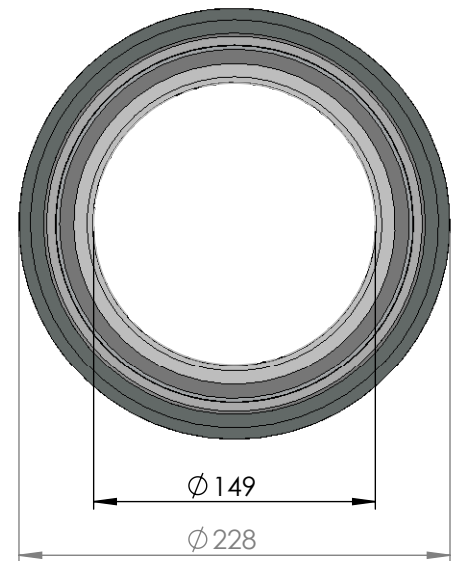
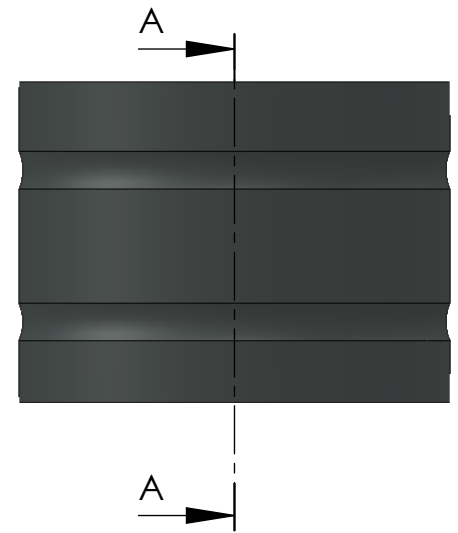

ITEM NO.	PART NUMBER	PART NAME	QTY.
1	M01-340	Roller $\phi 10.5 \times 57\text{mm}$	94
2	M03-310	Lockring $\phi 156 \phi 174$	3
3	M05-347	L-ring $\phi 150 \phi 153.5 \phi 170$	4
4	M07-242	Washer $\phi 174.5 \phi 219$	1
5	M09-125	Alu lockring $\phi 180.5 \times \phi 189.5$	1
6	M15-140	Ball for 43125-43160	1
7	M25-120	Yderhus for 43125-43154	1
8	M27-160	Inderhus for 43145-43154	1

DWG NR / NAME:

43149 / Self-aligning roller bearing

BATCH NR:

PROJECT:

Shaft $\phi 149$ max working load 18200kg

REKV.NR / ORDRE NR:

DATE:
15-12-2009

NAME:
JR

SCALE / PAPER:
1:5 / A4

MATERIAL:
WEIGHT: g

LOCATION:

ORDRE DATO:

MODIFY DATE:

: /

REV:

LEV.DATO:

Jefa Rudder
SYSTEMS

JEFA MARINE A/S
NIMBUSVEJ 2
2670 GREVE, DENMARK

Tlf: +45 4615 5210 & Fax: +45 4615 5208
Email: info@jefa.com www.jefa.com