

SECTION A-A

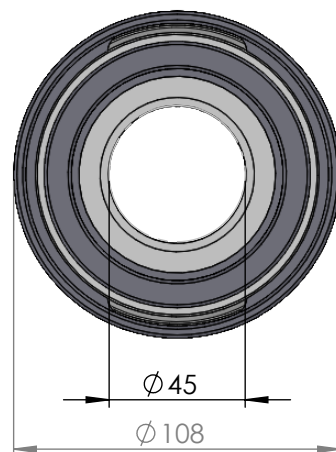

ITEM NO.	PART NUMBER	PART NAME	Expl /QTY
1	M35-101	Inner house 4S040-4S049	1
2	O-ring	ø75 x 2,5mm	1
3	M03-195	Delrin Lockring ø68,5 x ø51 x 1,75mm	2
4	M05-119	L-ring ø45 x ø65 x 7,5	2
5	M01-232	Roller Ø10 x 44mm	17
6	M11-101	Ball 4S040-4S059	1
7	O-ring	ø90 x 2,5mm	1
8	M09-101	Alu lockring ø80.5 x ø89.5	1
9	M31-101	Outer house 4S040-4S059	1
10	M07-110	Washer, delrin ø45,5 x ø79 x 4,5mm	1

DWG NR / NAME:

**4S045 / Self-aligning lower bearing**

BATCH NR:

PROJECT:

Shaft Ø45mm, max working load 2100kg

REKV.NR / ORDRE NR:

DATE:

27-08-2009

NAME:

JR

SCALE / PAPER:

1:2.5 / A4

MATERIAL:

WEIGHT:

g

LOCATION:

REV:

ORDRE DATO:

LEV.DATO:

*Jefa Rudder*  
SYSTEMS

JEFA MARINE A/S  
NIMBUSVEJ 2  
2670 GREVE, DENMARK

Tlf: +45 4615 5210 & Fax: +45 46155208  
Email: info@jefa.com www.jefa.com

: /