



1



2



3

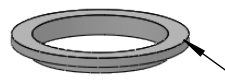

4

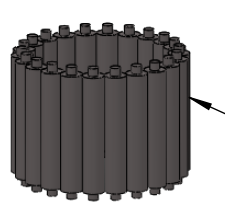

5



4



3

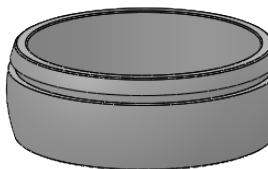

6



7



8



9

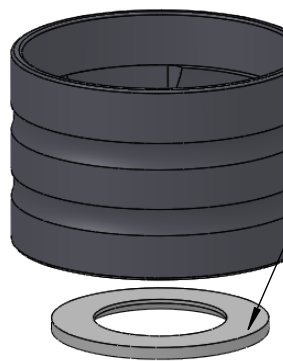

10

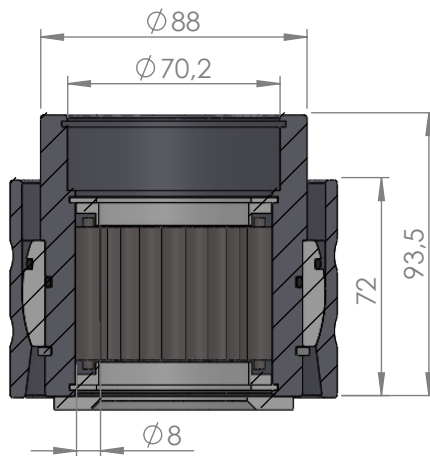

SECTION A-A

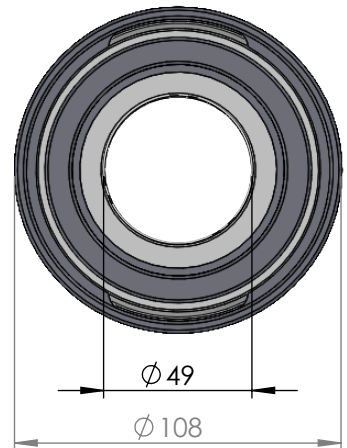

ITEM NO.	PART NUMBER	PART NAME	Expl /QTY
1	M35-101	Inner house 4S040-4S049	1
2	O-ring	$\phi 75 \times 2,5\text{mm}$	1
3	M03-195	Delrin Lockring $\phi 68,5 \times \phi 51 \times 1,75\text{mm}$	2
4	M05-125	L-ring $\phi 49 \times \phi 51.5 \phi 65$	2
5	M01-201	Roller $\phi 8 \times 44\text{mm}$	22
6	M11-101	Ball 4S040-4S059	1
7	O-ring	$\phi 90 \times 2,5\text{mm}$	1
8	M09-101	Alu lockring $\phi 80.5 \times \phi 89.5$	1
9	M31-101	Outer house 4S040-4S059	1
10	M07-113	Washer $\phi 49.5 \times \phi 79 \times 4,5$	1

DWG NR / NAME:

4S049 / Self-aligning lower bearing

BATCH NR:

PROJECT:

Shaft $\phi 49\text{mm}$, max working load 2100kg

REKV.NR / ORDRE NR:

DATE:

27-08-2009

NAME:

JR

SCALE / PAPER:

1:2.5 / A4

MATERIAL:

WEIGHT:

g

LOCATION:

REV:

ORDRE DATO:

LEV.DATO:

Jefa Rudder
SYSTEMS

JEFA MARINE A/S
NIMBUSVEJ 2
2670 GREVE, DENMARK

Tlf: +45 4615 5210 & Fax: +45 46155208
Email: info@jefa.com www.jefa.com

: /