

SECTION A-A

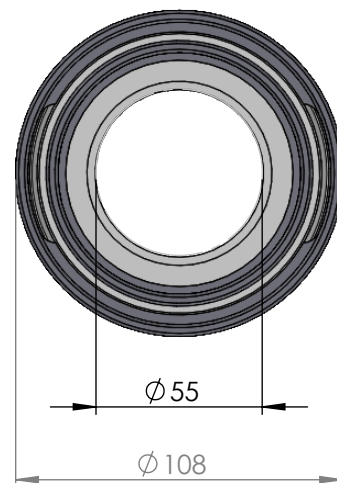
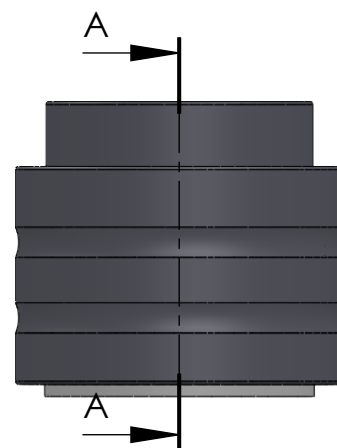

ITEM NO.	PART NUMBER	PART NAME	Expl /QTY
1	M35-103	Inner house 4S050-4S059	1
2	O-ring	$\varnothing 75 \times 2,5\text{mm}$	1
3	M03-201	Delrin Lockring $\varnothing 78,5 \times \varnothing 61 \times 1,75\text{mm}$	2
4	M05-140	L-ring $\varnothing 55 \varnothing 58.5 \varnothing 75$	2
5	M01-232	Roller $\varnothing 10 \times 44\text{mm}$	20
6	M11-101	Ball 4S040-4S059	1
7	O-ring	$\varnothing 90 \times 2,5\text{mm}$	1
8	M09-101	Alu lockring $\varnothing 80.5 \times \varnothing 89.5$	1
9	M31-101	Outer house 4S040-4S059	1
10	M07-122	Washer $\varnothing 55.5 \times \varnothing 89$	1

DWG NR / NAME:

**4S055 / Self-aligning lower bearing**

BATCH NR:

PROJECT:

Shaft  $\varnothing 55\text{mm}$ , max working load 2600kg

REKV.NR / ORDRE NR:

DATE:

27-08-2009

NAME:

JR

SCALE / PAPER:

1:2.5 / A4

MATERIAL:

WEIGHT:

g

LOCATION:

REV:

ORDRE DATO:

LEV.DATO:

*Jefa Rudder*  
SYSTEMS

JEFA MARINE A/S  
NIMBUSVEJ 2  
2670 GREVE, DENMARK

Tlf: +45 4615 5210 & Fax: +45 46155208  
Email: info@jefa.com www.jefa.com

: /