

SECTION A-A

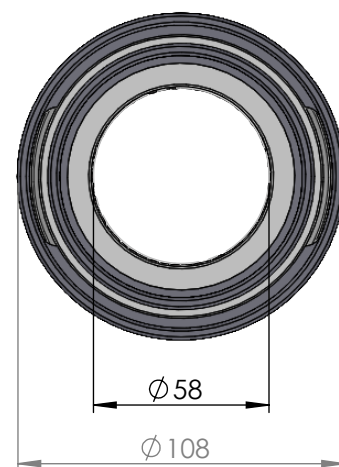
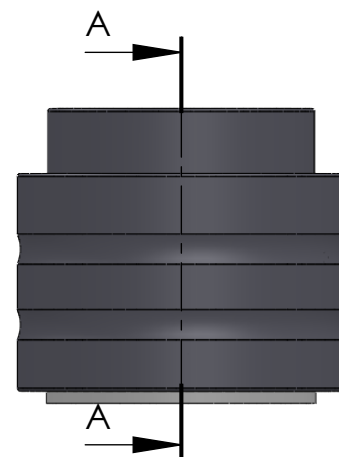

ITEM NO.	PART NUMBER	PART NAME	Expl / QTY
1	M35-103	Inner house 4S050-4S059	1
2	O-ring	$\phi 75 \times 2,5\text{mm}$	1
3	M03-201	Delrin Lockring $\phi 78,5 \times \phi 61 \times 1,75\text{mm}$	2
4	M05-149	L-ring $\phi 59 \phi 61.5 \phi 75$	2
5	M01-208	Roller $\phi 8.5 \times 44\text{mm}$	25
6	M11-101	Ball 4S040-4S059	1
7	O-ring	$\phi 90 \times 2,5\text{mm}$	1
8	M09-101	Alu lockring $\phi 80.5 \times \phi 89.5$	1
9	M31-101	Outer house 4S040-4S059	1
10	M07-127	Washer $\phi 58.5 \phi 89$	1

DWG NR / NAME:

**4S058 / Self-aligning lower bearing**

BATCH NR:

PROJECT:

Shaft  $\phi 58\text{mm}$ , max working load 2600kg

REKV.NR / ORDRE NR:

DATE:

27-08-2009

NAME:

JR

SCALE / PAPER:

1:2.5 / A4

MATERIAL:

WEIGHT:

g

LOCATION:

REV:

ORDRE DATO:

LEV.DATO:

MODIFY DATE:

: /

*Jefa Rudder*  
SYSTEMS

JEFA MARINE A/S  
NIMBUSVEJ 2  
2670 GREVE, DENMARK

Tlf: +45 4615 5210 & Fax: +45 4615 5208  
Email: info@jefa.com www.jefa.com