

SECTION A-A
SCALE 1 : 2.75

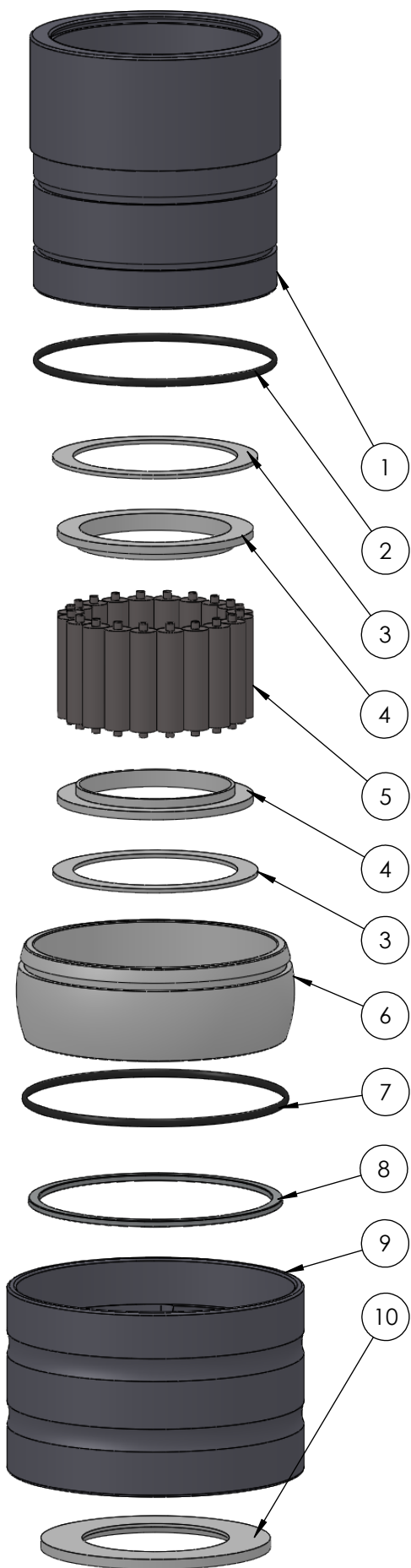
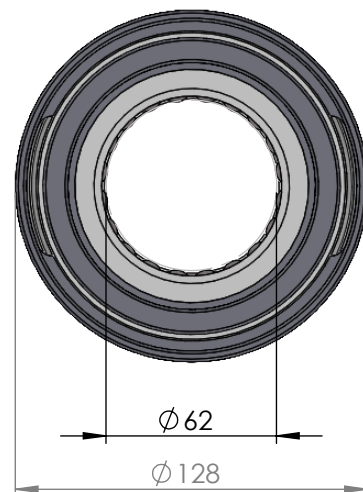

| ITEM NO. | PART NUMBER | PART NAME | Expl /QTY |
|----------|-------------|---|-----------|
| 1 | M35-105 | Inner house 4S060-4S069 | 1 |
| 2 | O-ring | $\phi 90 \times 2,5\text{mm}$ | 1 |
| 3 | M03-207 | Delrin Lockring $\phi 88,5 \times \phi 71 \times 1,75\text{mm}$ | 2 |
| 4 | M05-164 | L-ring $\phi 65 \phi 68.5 \phi 85$ | 2 |
| 5 | M01-256 | Roller $\phi 11.5 \times 44\text{mm}$ | 20 |
| 6 | M11-103 | Ball 4S060-4S079 | 1 |
| 7 | O-ring | $\phi 100 \times 2.5$ | 1 |
| 8 | M09-105 | Alu lockring $\phi 100,5 \times \phi 109,5$ | 1 |
| 9 | M31-106 | Outer house 4S060-4S079 | 1 |
| 10 | M07-134 | Washer $\phi 63.5 \phi 99$ | 1 |

DWG NR / NAME:

4S062 / Self-aligning lower bearing

BATCH NR:

PROJECT:

Shaft $\phi 62\text{mm}$, max working load 4200kg

REKV.NR / ORDRE NR:

DATE:
27-08-2009

NAME:
JR

SCALE / PAPER:
1:3 / A4

MATERIAL:
WEIGHT: g

LOCATION:

ORDRE DATO:

MODIFY DATE:

REV:

LEV.DATO:

: /

Jefa Rudder
SYSTEMS

JEFA MARINE A/S
NIMBUSVEJ 2
2670 GREVE, DENMARK

Tlf: +45 4615 5210 & Fax: +45 4615 5208
Email: info@jefa.com www.jefa.com