

SECTION A-A  
SCALE 1 : 2.75

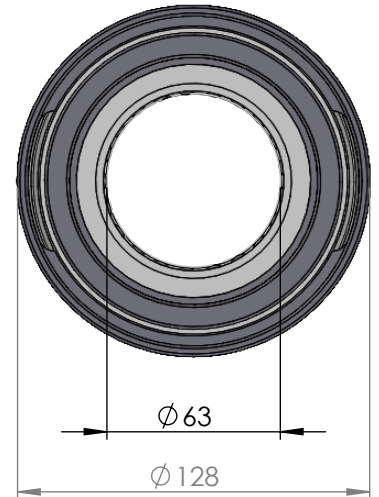

ITEM NO.	PART NUMBER	PART NAME	Expl /QTY
1	M35-105	Inner house 4S060-4S069	1
2	O-ring	$\varnothing 90 \times 2,5\text{mm}$	1
3	M03-207	Delrin Lockring $\varnothing 88,5 \times \varnothing 71 \times 1,75\text{mm}$	2
4	M05-164	L-ring $\varnothing 65 \varnothing 68.5 \varnothing 85$	2
5	M01-248	Roller $\varnothing 11 \times 44\text{mm}$	21
6	M11-103	Ball 4S060-4S079	1
7	O-ring	$\varnothing 100 \times 2.5$	1
8	M09-105	Alu lockring $\varnothing 100,5 \times \varnothing 109,5$	1
9	M31-106	Outer house 4S060-4S079	1
10	M07-134	Washer $\varnothing 63.5 \varnothing 99$	1

DWG NR / NAME:

## 4S063 / Self-aligning lower bearing

BATCH NR:

PROJECT:

Shaft  $\varnothing 63\text{mm}$ , max working load 4200kg

REKV.NR / ORDRE NR:

DATE:

27-08-2009

NAME:

JR

SCALE / PAPER:

1:3 / A4

MATERIAL:

WEIGHT:

g

LOCATION:

ORDRE DATO:

MODIFY DATE:

: /

REV:

LEV.DATO:

*Jefa Rudder*  
SYSTEMS

JEFA MARINE A/S  
NIMBUSVEJ 2  
2670 GREVE, DENMARK

Tlf: +45 4615 5210 & Fax: +45 4615 5208  
Email: info@jefa.com www.jefa.com