

SECTION A-A
SCALE 1 : 2.75

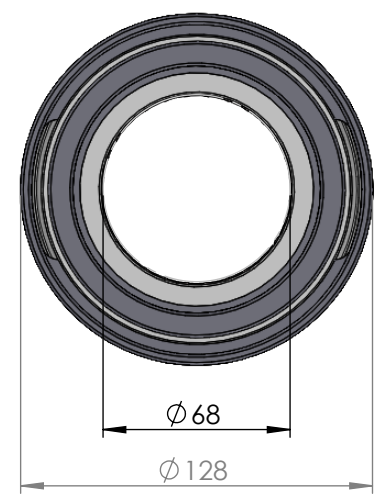
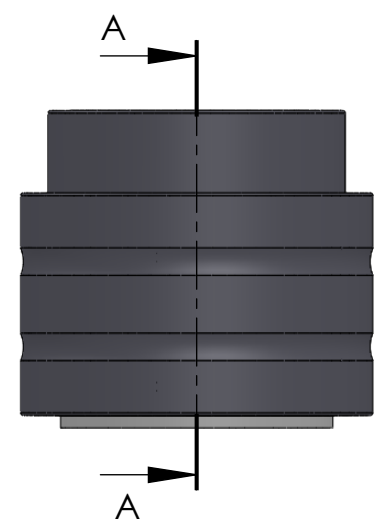

ITEM NO.	PART NUMBER	PART NAME	Expl /QTY
1	M35-105	Inner house 4S060-4S069	1
2	O-ring	$\varnothing 90 \times 2,5\text{mm}$	1
3	M03-207	Delrin Lockring $\varnothing 88,5 \times \varnothing 71 \times 1,75\text{mm}$	2
4	M05-170	L-ring $\varnothing 69 \varnothing 71.5 \varnothing 85$	2
5	M01-208	Roller $\varnothing 8.5 \times 44\text{mm}$	28
6	M11-103	Ball 4S060-4S079	1
7	O-ring	$\varnothing 100 \times 2.5$	1
8	M09-105	Alu lockring $\varnothing 100,5 \times \varnothing 109,5$	1
9	M31-106	Outer house 4S060-4S079	1
10	M07-142	Washer $\varnothing 68.5 \varnothing 99$	1

DWG NR / NAME:

4S068 / Self-aligning lower bearing

BATCH NR:

PROJECT:
Shaft $\varnothing 68\text{mm}$, max working load 4200kg

REKV.NR / ORDRE NR:

DATE:
27-08-2009

NAME:
JR

SCALE / PAPER:
1:3 / A4

MATERIAL:
WEIGHT: g

LOCATION:

ORDRE DATO:

MODIFY DATE:
: /

REV:

LEV.DATO:



JEFA MARINE A/S
NIMBUSVEJ 2
2670 GREVE, DENMARK

Tlf: +45 4615 5210 & Fax: +45 46155208
Email: info@jefa.com www.jefa.com