

SECTION A-A  
SCALE 1 : 2.75

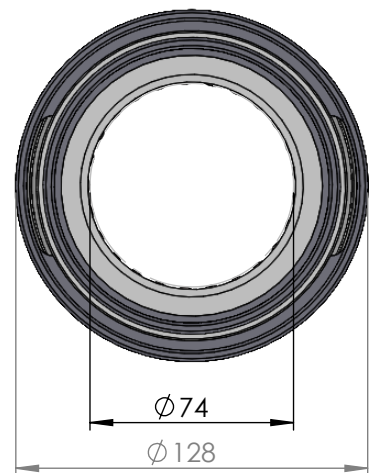
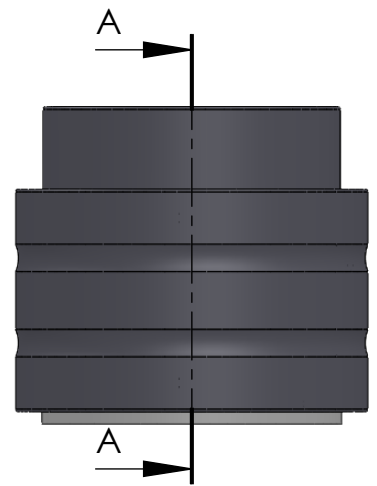

ITEM NO.	PART NUMBER	PART NAME	Expl / QTY
1	M35-107	Inner house 4S070-4S079	1
2	O-ring	$\phi 90 \times 2,5\text{mm}$	1
3	M03-213	Delrin Lockring $\phi 98,5 \times \phi 81 \times 1,75\text{mm}$	2
4	M05-182	L-ring, delrin $\phi 75 \times \phi 95 \times 7,5\text{mm}$	2
5	M01-340	Roller $\phi 10.5 \times 57\text{mm}$	25
6	M11-103	Ball 4S060-4S079	1
7	O-ring	$\phi 100 \times 2.5\text{mm}$	1
8	M09-105	Alu lockring $\phi 100,5 \times \phi 109,5$	1
9	M31-106	Outer house 4S060-4S079	1
10	M07-152	Washer, delrin $\phi 75,5 \times \phi 109 \times 4,5\text{mm}$	1

DWG NR / NAME:

## 4S074 / Self-aligning lower bearing

BATCH NR:

PROJECT:

Shaft  $\phi 74\text{mm}$ , max working load 4900kg

REKV.NR / ORDRE NR:

DATE:

27-08-2009

NAME:

JR

SCALE / PAPER:

1:3 / A4

MATERIAL:

WEIGHT:

g

LOCATION:

REV:

ORDRE DATO:

LEV.DATO:

*Jefa Rudder*  
SYSTEMS

JEFA MARINE A/S  
NIMBUSVEJ 2  
2670 GREVE. DENMARK

Tlf: +45 4615 5210 & Fax: +45 46155208  
Email: info@jefa.com www.jefa.com

: /