

SECTION A-A

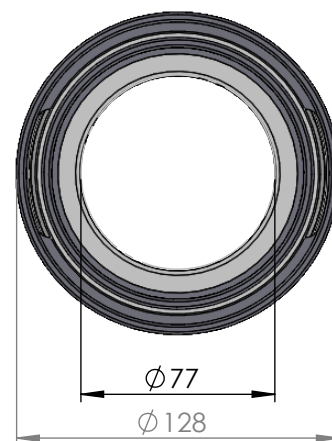

ITEM NO.	PART NUMBER	PART NAME	Expl / QTY
1	M35-107	Inner house 4S070-4S079	1
2	O-ring	$\varnothing 90 \times 2,5\text{mm}$	1
3	M03-213	Delrin Lockring $\varnothing 98,5 \times \varnothing 81 \times 1,75\text{mm}$	2
4	M05-185	L-ring, delrin $\varnothing 77 \times \varnothing 95 \times 7,5\text{mm}$	2
5	M01-316	Roller $\varnothing 9.0 \times 57\text{mm}$	30
6	M11-103	Ball 4S060-4S079	1
7	O-ring	$\varnothing 100 \times 2.5\text{mm}$	1
8	M09-105	Alu lockring $\varnothing 100,5 \times \varnothing 109,5$	1
9	M31-106	Outer house 4S060-4S079	1
10	M07-155	Washer, delrin $\varnothing 77,5 \times \varnothing 109 \times 4,5\text{mm}$	1

DWG NR / NAME:

4S077 / Self-aligning lower bearing

BATCH NR:

PROJECT:

Shaft $\varnothing 77\text{mm}$, max working load 4900kg

REKV.NR / ORDRE NR:

DATE:

27-08-2009

NAME:

JR

SCALE / PAPER:

1:3 / A4

MATERIAL:

WEIGHT:

g

LOCATION:

ORDRE DATO:

MODIFY DATE:

: /

REV:

LEV.DATO:

Jefa Rudder
S Y S T E M S

JEFA MARINE A/S
NIMBUSVEJ 2
2670 GREVE. DENMARK

Tlf: +45 4615 5210 & Fax: +45 46155208
Email: info@jefa.com www.jefa.com