

SECTION A-A
SCALE 1 : 2.75

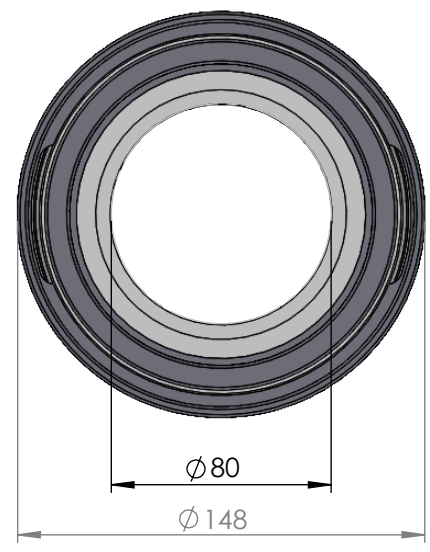
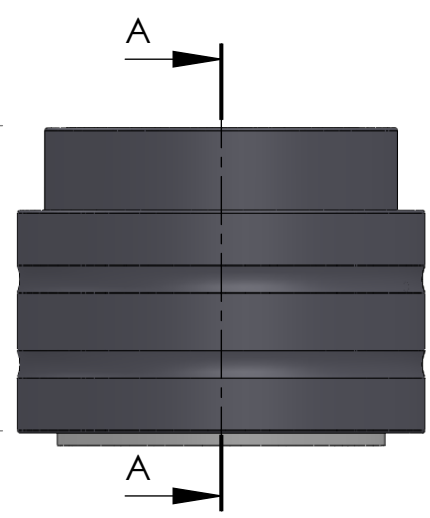

ITEM NO.	PART NUMBER	PART NAME	Expl /QTY
1	M35-109	Inner house 4S080-4S089	1
2	O-ring	$\varnothing 115 \times 2.5\text{mm}$	1
3	M03-220	Delrin Lockring $\varnothing 108,5 \times \varnothing 91 \times 1,75\text{mm}$	2
4	M05-191	L-ring $\varnothing 80 \varnothing 83.5 \varnothing 105$	2
5	M01-372	Roller $\varnothing 12.5 \times 57\text{mm}$	22
6	M11-105	Ball 4S070-4S099	1
7	O-ring	$\varnothing 120 \times 2.5\text{mm}$	1
8	M09-110	Alu lockring $\varnothing 122.5 \times \varnothing 131.5$	1
9	M31-111	Outer house 4S080-4S099	1
10	M07-161	Washer, delrin $\varnothing 80,5 \times \varnothing 119 \times 4,5\text{mm}$	1

DWG NR / NAME:

4S080 / Self-aligning lower bearing

BATCH NR:

PROJECT:
Shaft $\varnothing 80\text{mm}$, max working load 5600kg

REKV.NR / ORDRE NR:

DATE:
27-08-2009

NAME:
JR

SCALE / PAPER:
1:3 / A4

MATERIAL:
WEIGHT: g

LOCATION:

ORDRE DATO:

MODIFY DATE:
: /

REV:

LEV.DATO:



JEFA MARINE A/S
NIMBUSVEJ 2
2670 GREVE. DENMARK

Tlf: +45 4615 5210 & Fax: +45 46155208
Email: info@jefa.com www.jefa.com