

SECTION A-A
SCALE 1 : 2.75

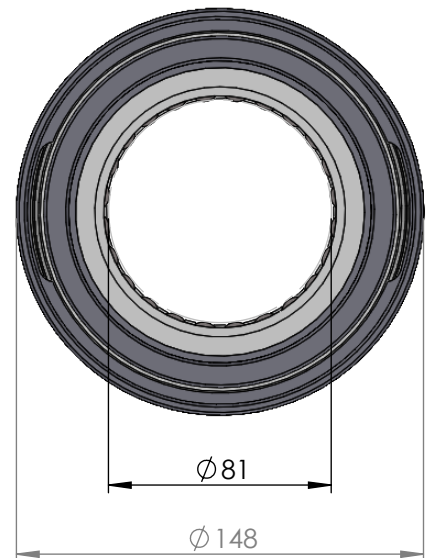
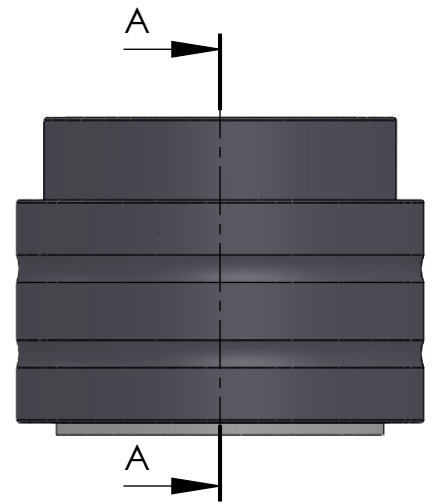

ITEM NO.	PART NUMBER	PART NAME	Expl / QTY
1	M35-109	Inner house 4S080-4S089	1
2	O-ring	$\varnothing 115 \times 2.5\text{mm}$	1
3	M03-220	Delrin Lockring $\varnothing 108,5 \times \varnothing 91 \times 1,75\text{mm}$	2
4	M05-194	L-ring, delrin $\varnothing 84 \times \varnothing 105 \times 7,5\text{mm}$	2
5	M01-364	Roller $\varnothing 12.0 \times 57\text{mm}$	24
6	M11-105	Ball 4S070-4S099	1
7	O-ring	$\varnothing 120 \times 2.5\text{mm}$	1
8	M09-110	Alu lockring $\varnothing 122.5 \times \varnothing 131.5$	1
9	M31-111	Outer house 4S080-4S099	1
10	M07-162	Washer, delrin $\varnothing 82,5 \times \varnothing 119 \times 4,5\text{mm}$	1

DWG NR / NAME:

4S081 / Self-aligning lower bearing

BATCH NR:

PROJECT:

Shaft $\varnothing 81\text{mm}$, max working load 5600kg

REKV.NR / ORDRE NR:

DATE:
27-08-2009

NAME:
JR

SCALE / PAPER:
1:3 / A4

MATERIAL:
WEIGHT: g

LOCATION:
REV:

ORDRE DATO:

LEV.DATO:

Jefa Rudder
SYSTEMS

JEFA MARINE A/S
NIMBUSVEJ 2
2670 GREVE, DENMARK

Tlf: +45 4615 5210 & Fax: +45 46155208
Email: info@jefa.com www.jefa.com

: /