

SECTION A-A  
SCALE 1 : 3

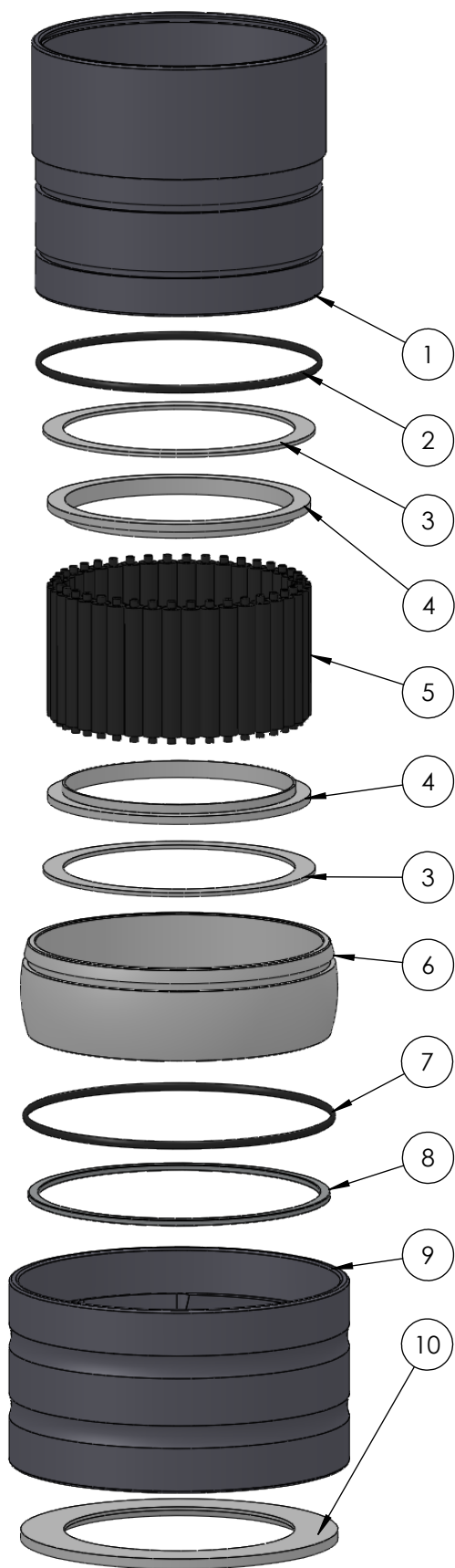
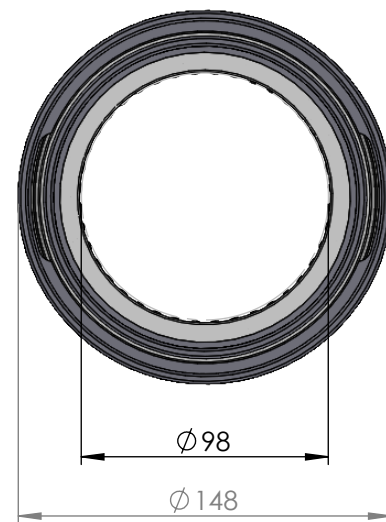
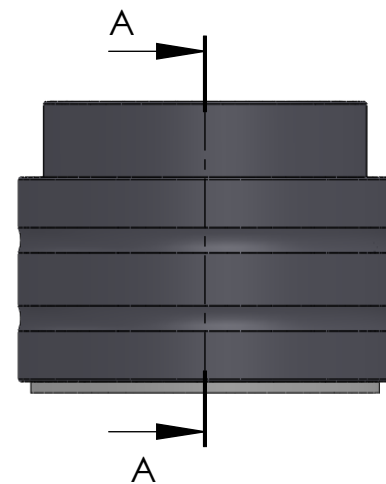

ITEM NO.	PART NUMBER	PART NAME	Expl /QTY
1	M35-111	Inner house 4S090-4S099	1
2	O-ring	$\varnothing 115 \times 2.5\text{mm}$	1
3	M03-228	Delrin Lockring $\varnothing 118,5 \times 101 \times 1,75\text{mm}$	2
4	M05-233	L-ring $\varnothing 99 \varnothing 101.5 \varnothing 115$	2
5	M01-308	Roller $\varnothing 8.5 \times 57\text{mm}$	40
6	M11-105	Ball 4S080-4S099	1
7	O-ring	$\varnothing 120 \times 2.5\text{mm}$	1
8	M09-110	Alu lockring $\varnothing 122.5 \times \varnothing 131.5$	1
9	M31-111	Outer house 4S080-4S099	1
10	M07-185	Washer $\varnothing 100.5 \varnothing 138$	1

DWG NR / NAME:

## 4S098 / Self-aligning lower bearing

BATCH NR:

PROJECT:

SHaft  $\varnothing 98\text{mm}$ , max working load 6200kg

REKV.NR / ORDRE NR:

DATE:

27-08-2009

NAME:

JR

SCALE / PAPER:

1:3.5 / A4

MATERIAL:

WEIGHT:

g

LOCATION:

REV:

ORDRE DATO:

LEV.DATO:

*Jefa Rudder*  
SYSTEMS

JEFA MARINE A/S  
NIMBUSVEJ 2  
2670 GREVE, DENMARK

Tlf: +45 4615 5210 & Fax: +45 4615 5208  
Email: info@jefa.com www.jefa.com

: /