

SECTION A-A  
SCALE 1 : 3

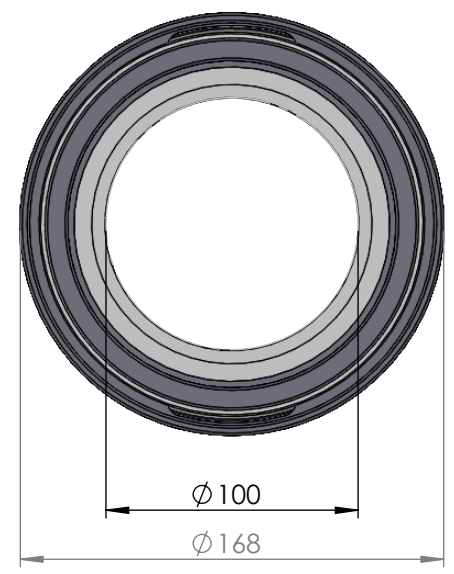
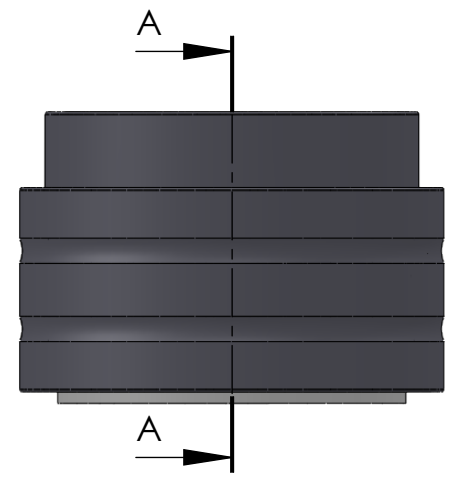

ITEM NO.	PART NUMBER	PART NAME	Expl /QTY
1	M35-113	Inner house 4S100-4S109	1
2	O-ring	ø130 x 2.5mm	1
3	M03-235	Delrin Lockring ø128,5 x ø111 x 1,75mm	2
4	M05-245	L-ring ø100 ø103.5 ø125	2
5	M01-372	Roller ø12.5 x 57mm	28
6	M11-107	Ball 4S100-4S119	1
7	O-ring	ø140 x 2.5mm	1
8	M09-115	Alu lockring ø140.5 x ø149.5	1
9	M31-116	Outer house 4S100-4S119	1
10	M07-185	Washer ø100.5 ø138	1

DWG NR / NAME:

### 4S100 / Self-aligning lower bearing

BATCH NR:

PROJECT:  
Shaft Ø100mm, max working load 6800kg

REKV.NR / ORDRE NR:

DATE:  
27-08-2009

NAME:  
JR

SCALE / PAPER:  
1:3.5 / A4

MATERIAL:  
WEIGHT: g

LOCATION:

ORDRE DATO:

MODIFY DATE:  
: /

REV:

LEV.DATO:

*Jefa Rudder*  
SYSTEMS

JEFA MARINE A/S  
NIMBUSVEJ 2  
2670 GREVE, DENMARK

Tlf: +45 4615 5210 & Fax: +45 46155208  
Email: info@jefa.com www.jefa.com