

A

B

C

D

E

F

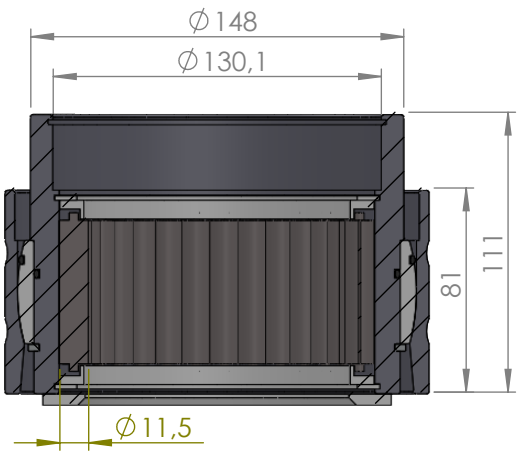
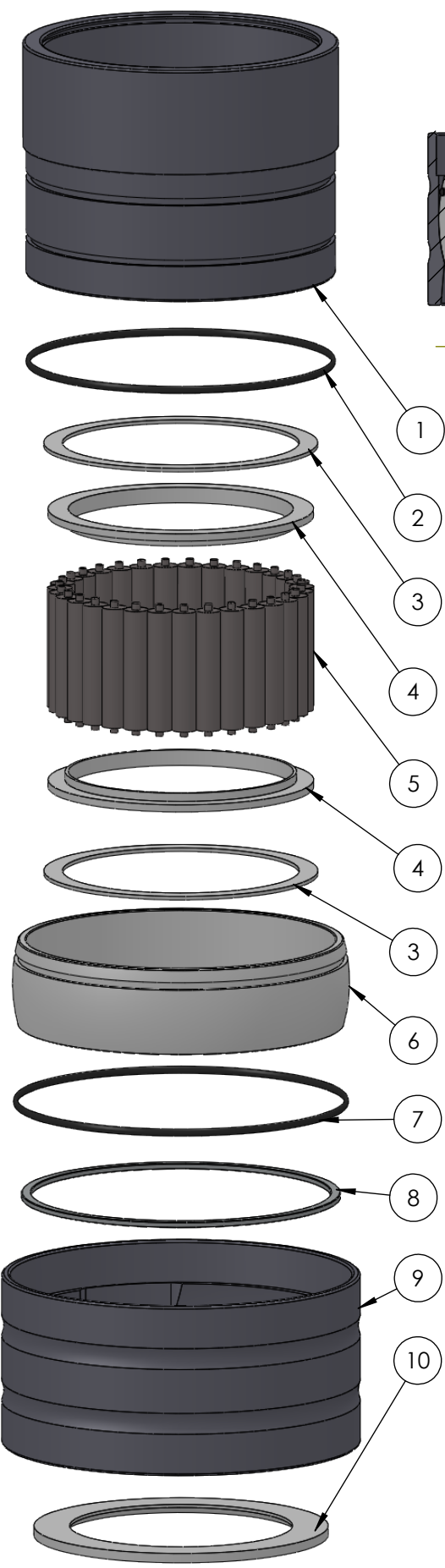

SECTION A-A
SCALE 1 : 3

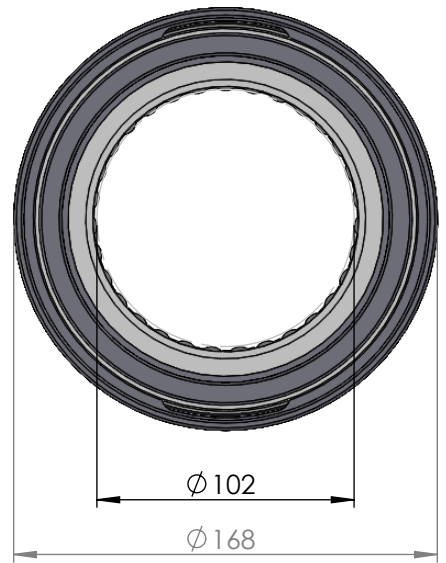
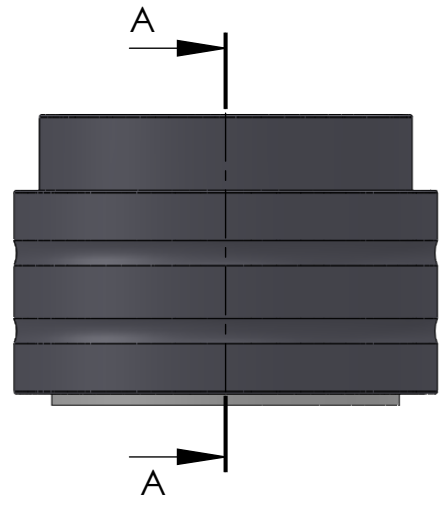

ITEM NO.	PART NUMBER	PART NAME	Expl /QTY
1	M35-113	Inner house 4S100-4S109	1
2	O-ring	$\varnothing 130 \times 2.5\text{mm}$	1
3	M03-235	Delrin Lockring $\varnothing 128,5 \times \varnothing 111 \times 1,75\text{mm}$	2
4	M05-257	L-ring $\varnothing 105 \varnothing 108.5 \varnothing 125$	2
5	M01-356	Roller $\varnothing 11.5 \times 57\text{mm}$	31
6	M11-107	Ball 4S100-4S119	1
7	O-ring	$\varnothing 140 \times 2.5\text{mm}$	1
8	M09-115	Alu lockring $\varnothing 140.5 \times \varnothing 149.5$	1
9	M31-116	Outer house 4S100-4S119	1
10	M07-188	Washer $\varnothing 104.5 \varnothing 138$	1

DWG NR / NAME:

4S102 / Self-aligning lower bearing

BATCH NR:

PROJECT:
Shaft $\varnothing 102\text{mm}$, max working load 6800kg

REKV.NR / ORDRE NR:

DATE:
27-08-2009

NAME:
JR

SCALE / PAPER:
1:3.5 / A4

MATERIAL:
WEIGHT: g

LOCATION:

ORDRE DATO:

MODIFY DATE:
: /

REV:

LEV.DATO:



JEFA MARINE A/S
NIMBUSVEJ 2
2670 GREVE, DENMARK

Tlf: +45 4615 5210 & Fax: +45 46155208
Email: info@jefa.com www.jefa.com