

SECTION A-A
SCALE 1 : 3

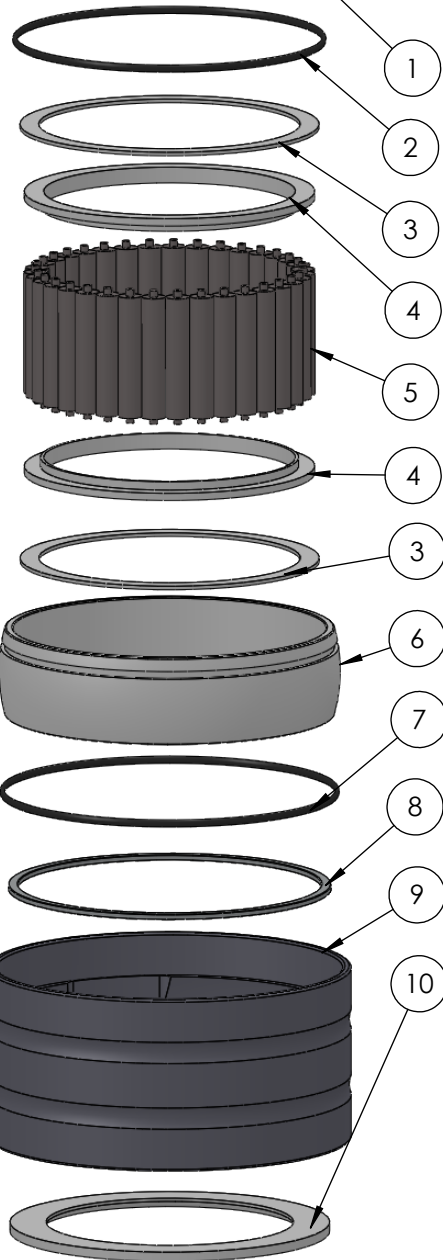
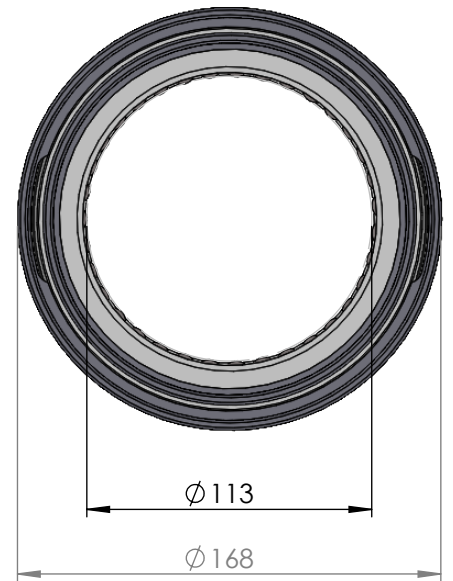

ITEM NO.	PART NUMBER	PART NAME	Expl /QTY
1	M35-115	Inner house 4S110-4S119	1
2	O-ring	$\varnothing 130 \times 2.5\text{mm}$	1
3	M03-275	Delrin Lockring $\varnothing 138,5 \times \varnothing 121 \times 1,75\text{mm}$	2
4	M05-284	L-ring $\varnothing 116 \varnothing 119.5 \varnothing 135$	2
5	M01-348	Roller $\varnothing 11.0 \times 57\text{mm}$	35
6	M11-107	Ball 4S100-4S119	1
7	O-ring	$\varnothing 140 \times 2.5\text{mm}$	1
8	M09-115	Alu lockring $\varnothing 140.5 \times \varnothing 149.5$	1
9	M31-116	Outer house 4S100-4S119	1
10	M07-200	Washer $\varnothing 114.5 \varnothing 148$	1

DWG NR / NAME:

4S113 / Self-aligning lower bearing

BATCH NR:

PROJECT:

Shaft $\varnothing 113\text{mm}$, max working load 7300kg

REKV.NR / ORDRE NR:

DATE:

27-08-2009

NAME:

JR

SCALE / PAPER:

1:3.5 / A4

MATERIAL:

WEIGHT:

g

LOCATION:

REV:

ORDRE DATO:

LEV.DATO:

Jefa Rudder
SYSTEMS

JEFA MARINE A/S
NIMBUSVEJ 2
2670 GREVE, DENMARK

Tlf: +45 4615 5210 & Fax: +45 46155208
Email: info@jefa.com www.jefa.com

MODIFY DATE:

: /