

SECTION A-A  
SCALE 1 : 3

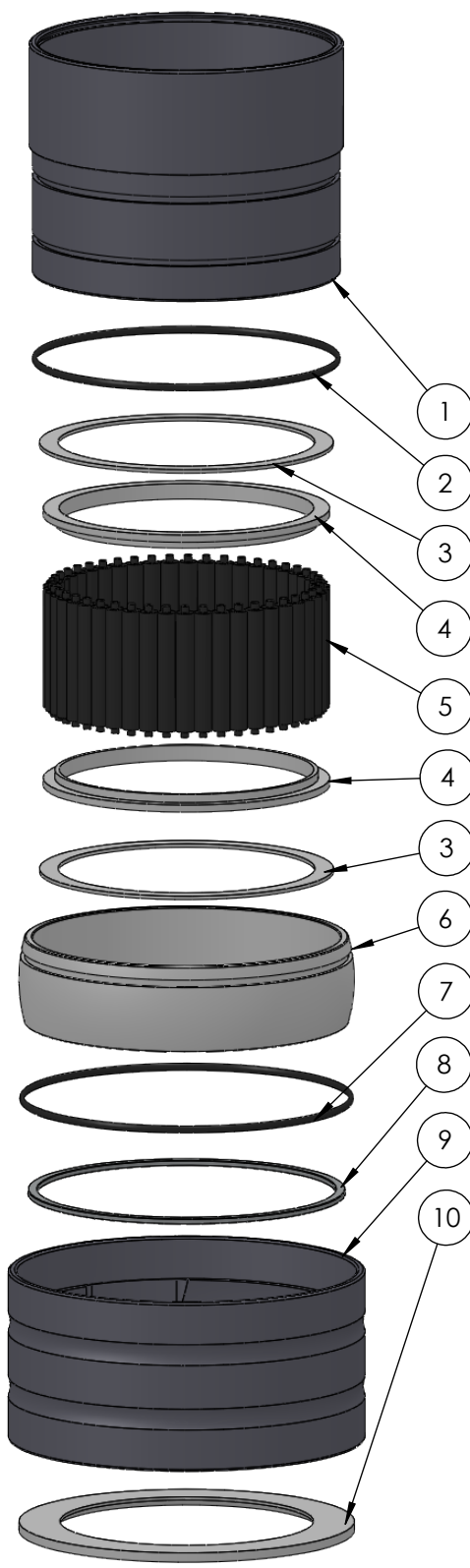

ITEM NO.	PART NUMBER	PART NAME	Expl /QTY
1	M35-115	Inner house 4S110-4S119	1
2	O-ring	ø130 x 2.5mm	1
3	M03-275	Delrin Lockring ø138,5 x ø121 x 1,75mm	2
4	M05-286	L-ring ø120 ø124 ø135	2
5	M01-308	Roller ø8.5 x 57mm	46
6	M11-107	Ball 4S100-4S119	1
7	O-ring	ø140 x 2.5mm	1
8	M09-115	Alu lockring ø140.5 x ø149.5	1
9	M31-116	Outer house 4S100-4S119	1
10	M07-206	Washer ø119.5 ø158	1

DWG NR / NAME:

**4S118 / Self-aligning lower bearing**

BATCH NR:

PROJECT:

Shaft Ø118mm, max working load 7300kg

REKV.NR / ORDRE NR:

DATE:

27-08-2009

NAME:

JR

SCALE / PAPER:

1:3.5 / A4

MATERIAL:

WEIGHT:

g

LOCATION:

ORDRE DATO:

MODIFY DATE:

: /

REV:

LEV.DATO:

*Jefa Rudder*  
SYSTEMS

JEFA MARINE A/S  
NIMBUSVEJ 2  
2670 GREVE, DENMARK

Tlf: +45 4615 5210 & Fax: +45 46155208  
Email: info@jefa.com www.jefa.com