

SECTION A-A  
SCALE 1 : 3.5

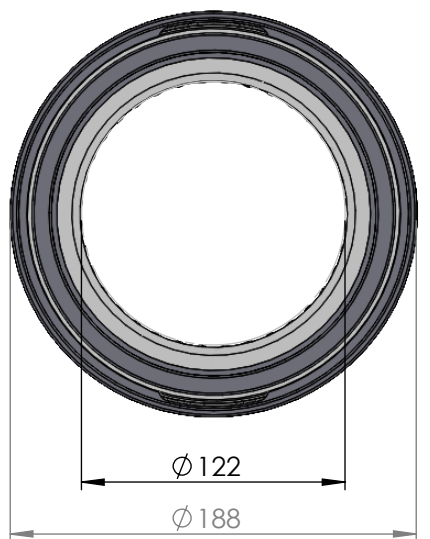
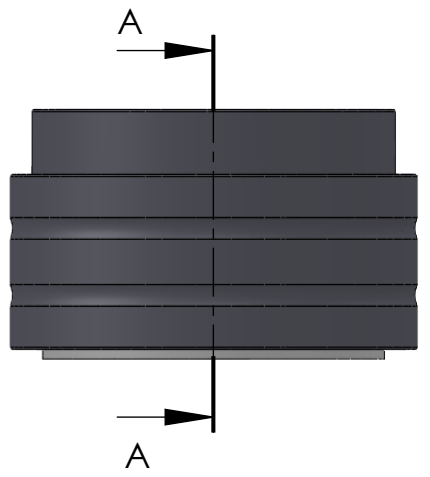

ITEM NO.	PART NUMBER	PART NAME	Expl /QTY
1	M35-117	Inner house 4S120-4S129	1
2	O-ring	$\varnothing 150 \times 2.5\text{mm}$	1
3	M03-285	Delrin Lockring $\varnothing 148,5 \times \varnothing 131 \times 1,75\text{mm}$	2
4	M05-296	L-ring $\varnothing 123 \varnothing 126.5 \varnothing 145$	2
5	M01-356	Roller $\varnothing 11.5 \times 57\text{mm}$	36
6	M11-109	Ball 4S120-4S139	1
7	O-ring	$\varnothing 160 \times 2.5\text{mm}$	1
8	M09-120	Alu lockring $\varnothing 160.5 \times \varnothing 169.5$	1
9	M31-121	Outer house 4S120-4S139	1
10	M07-212	Washer $\varnothing 124.5 \varnothing 158$	1

DWG NR / NAME:

**4S122 / Self-aligning lower bearing**

BATCH NR:

PROJECT:  
Shaft  $\varnothing 122\text{mm}$ , max working load 7900kg

REKV.NR / ORDRE NR:

DATE:  
27-08-2009

NAME:  
JR

SCALE / PAPER:  
1:4 / A4

MATERIAL:  
WEIGHT: g

LOCATION:

ORDRE DATO:

MODIFY DATE:  
: /

REV:

LEV.DATO:



JEFA MARINE A/S  
NIMBUSVEJ 2  
2670 GREVE, DENMARK

Tlf: +45 4615 5210 & Fax: +45 46155208  
Email: info@jefa.com www.jefa.com