

SECTION A-A
SCALE 1 : 3.5

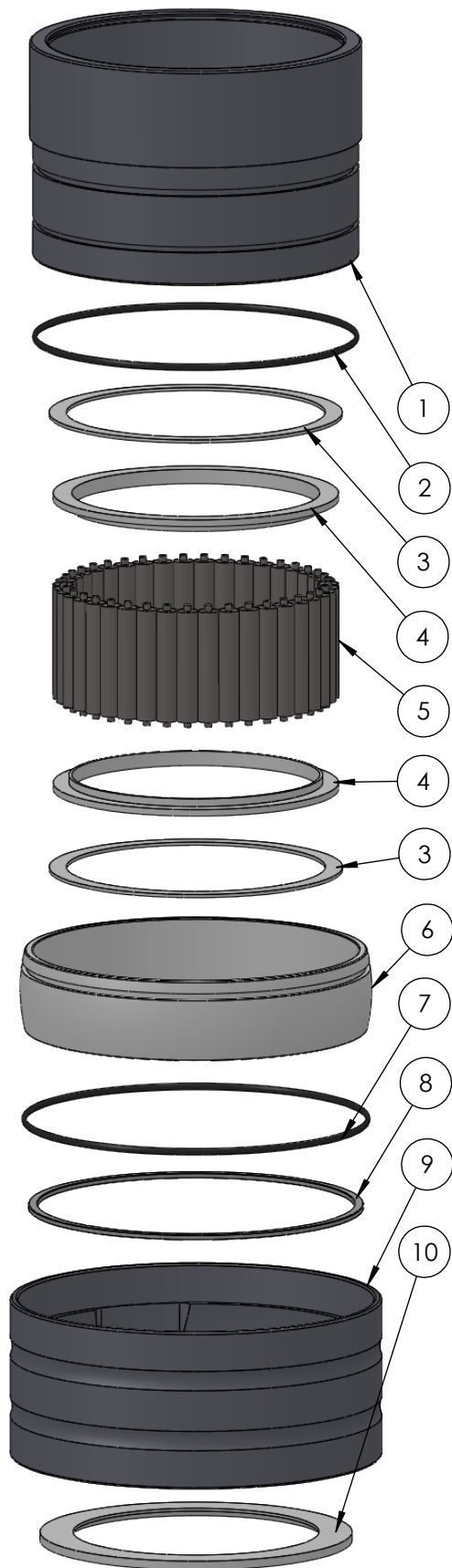

ITEM NO.	PART NUMBER	PART NAME	Expl /QTY
1	M35-117	Inner house 4S120-4S129	1
2	O-ring	$\varnothing 150 \times 2,5\text{mm}$	1
3	M03-285	Delrin Lockring $\varnothing 148,5 \times \varnothing 131 \times 1,75\text{mm}$	2
4	M05-302	L-ring $\varnothing 125 \varnothing 128.5 \varnothing 145$	2
5	M01-340	Roller $\varnothing 10.5 \times 57\text{mm}$	40
6	M11-109	Ball 4S120-4S139	1
7	O-ring	$\varnothing 160 \times 2,5\text{mm}$	1
8	M09-120	Alu lockring $\varnothing 160.5 \times \varnothing 169.5$	1
9	M31-121	Outer house 4S120-4S139	1
10	M07-212	Washer $\varnothing 124.5 \varnothing 158$	1

DWG NR / NAME:

4S124 / Self-aligning lower bearing

BATCH NR:

PROJECT:

Shaft $\varnothing 124\text{mm}$, max working load 7900kg

REKV.NR / ORDRE NR:

DATE:

27-08-2009

NAME:

JR

SCALE / PAPER:

1:4 / A4

MATERIAL:

WEIGHT:

g

LOCATION:

REV:

ORDRE DATO:

LEV.DATO:

MODIFY DATE:

: /

Jefa Rudder
SYSTEMS

JEFA MARINE A/S
NIMBUSVEJ 2
2670 GREVE, DENMARK

Tlf: +45 4615 5210 & Fax: +45 4615 5208
Email: info@jefa.com www.jefa.com