

SECTION A-A  
SCALE 1 : 3.5

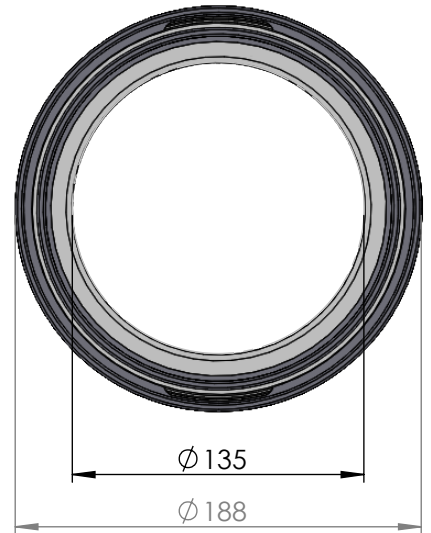
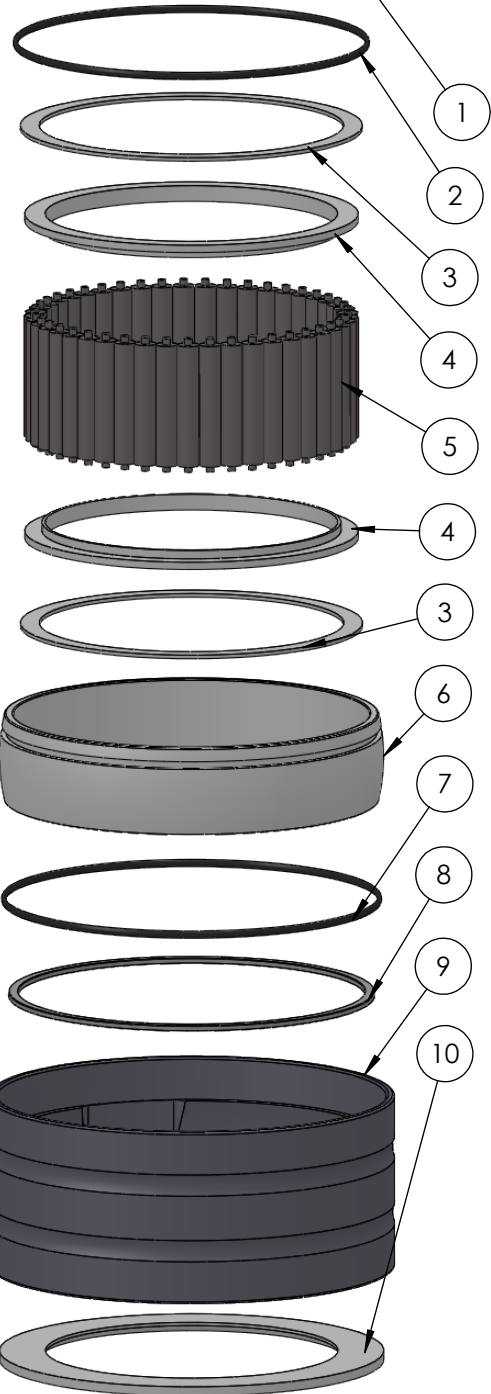

ITEM NO.	PART NUMBER	PART NAME	QTY
1	M35-119	Inner house 4S130-4S139	1
2	O-ring	$\varnothing 150 \times 2.5\text{mm}$	1
3	M03-295	Delrin Lockring $\varnothing 158,5 \times \varnothing 141 \times 1,75\text{mm}$	2
4	M05-320	L-ring $\varnothing 135 \varnothing 138.5 \varnothing 155$	2
5	M01-332	Roller $\varnothing 10.0 \times 57\text{mm}$	45
6	M11-109	Ball 4S120-4S139	1
7	O-ring	$\varnothing 160 \times 2.5\text{mm}$	1
8	M09-120	Alu lockring $\varnothing 160.5 \times \varnothing 169.5$	1
9	M31-121	Outer house 4S120-4S139	1
10	M07-224	Washer $\varnothing 135 \times \varnothing 178 \times 4,5$	1

DWG NR / NAME:

## 4S135 / Self-aligning lower bearing

BATCH NR:

PROJECT:

Shaft  $\varnothing 135\text{mm}$ , max working load 8400kg

REKV.NR / ORDRE NR:

DATE:

27-08-2009

NAME:

JR

SCALE / PAPER:

1:4 / A4

MATERIAL:

WEIGHT:

g

LOCATION:

ORDRE DATO:

MODIFY DATE:

: /

REV:

LEV.DATO:

*Jefa Rudder*  
SYSTEMS

JEFA MARINE A/S  
NIMBUSVEJ 2  
2670 GREVE, DENMARK

Tlf: +45 4615 5210 & Fax: +45 4615 5208  
Email: info@jefa.com www.jefa.com