

A

B

C

D

E

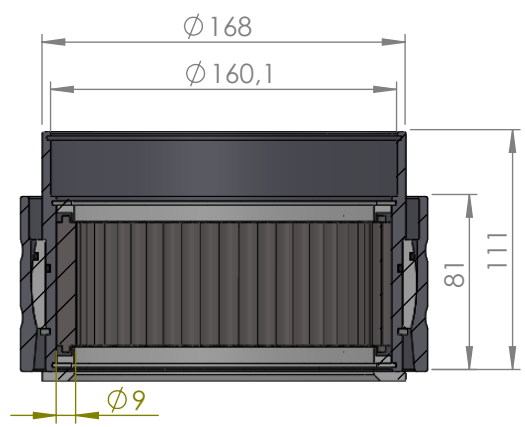

SECTION A-A
SCALE 1 : 3.5

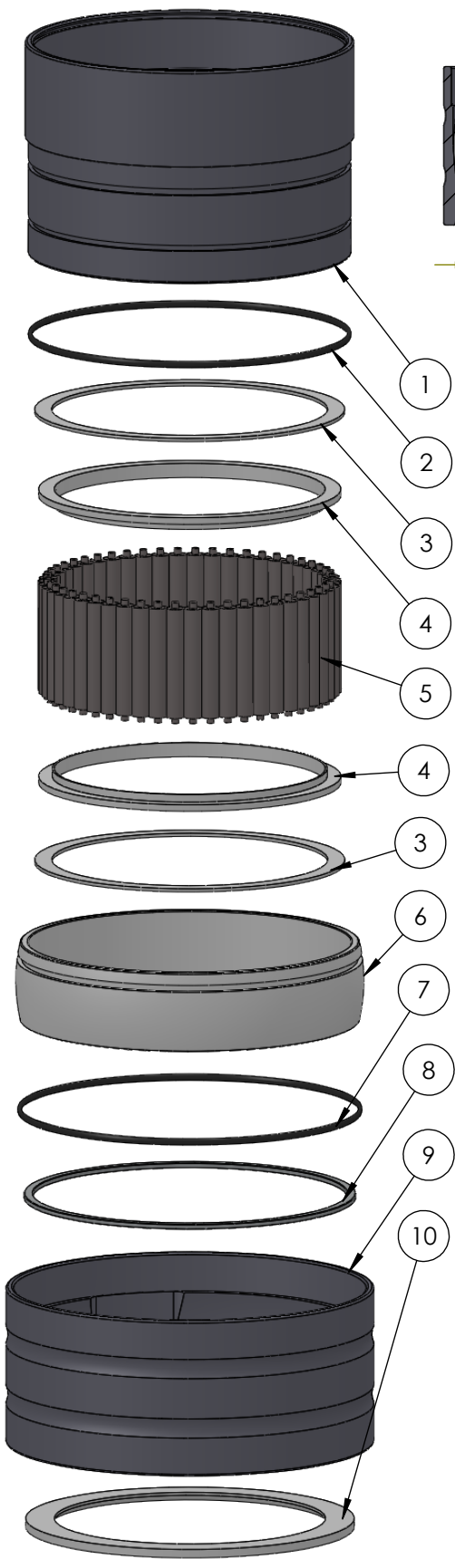
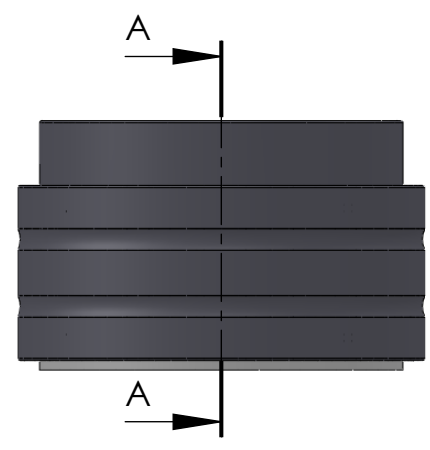

ITEM NO.	PART NUMBER	PART NAME	QTY
1	M35-119	Inner house 4S130-4S139	1
2	O-ring	ø150 x 2.5mm	1
3	M03-295	Delrin Lockring ø158,5 x ø141 x 1,75mm	2
4	M05-326	L-ring ø138 ø140 ø155	2
5	M01-316	Roller ø9.0 x 57mm	51
6	M11-109	Ball 4S120-4S139	1
7	O-ring	ø160 x 2.5mm	1
8	M09-120	Alu lockring ø160.5 x ø169.5	1
9	M31-121	Outer house 4S120-4S139	1
10	M07-227	Washer ø138 ø168	1

DWG NR / NAME:

4S137 / Self-aligning lower bearing

BATCH NR:

PROJECT:
Shaft Ø137mm, max working load 8400kg

REKV.NR / ORDRE NR:

DATE:
27-08-2009

NAME:
JR

SCALE / PAPER:
1:4 / A4

MATERIAL:
WEIGHT: g

LOCATION:

ORDRE DATO:

MODIFY DATE:
: /

REV:

LEV.DATO:



JEFA MARINE A/S
NIMBUSVEJ 2
2670 GREVE, DENMARK

Tlf: +45 4615 5210 & Fax: +45 46155208
Email: info@jefa.com www.jefa.com