

A

B

C

D

E

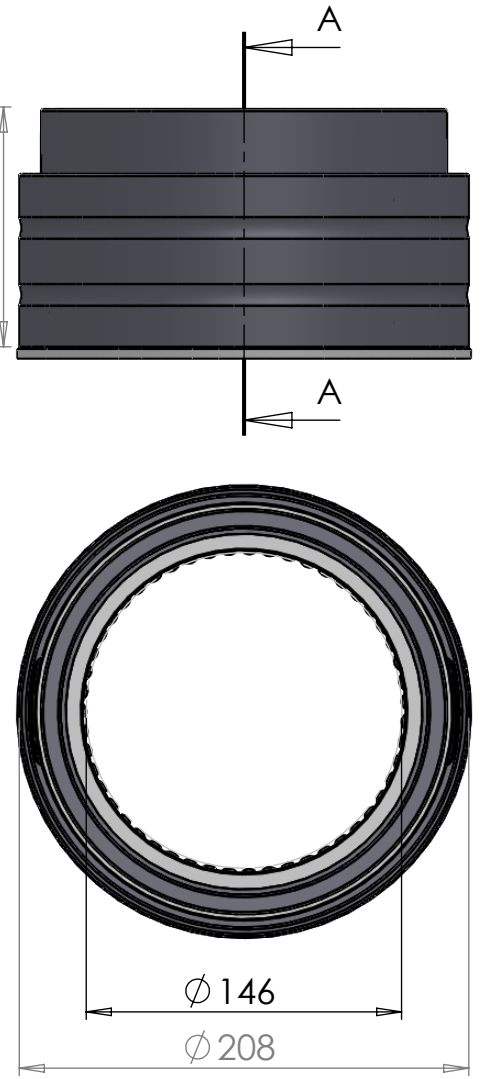
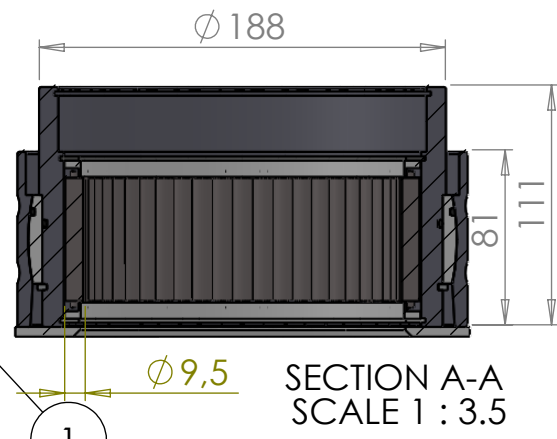
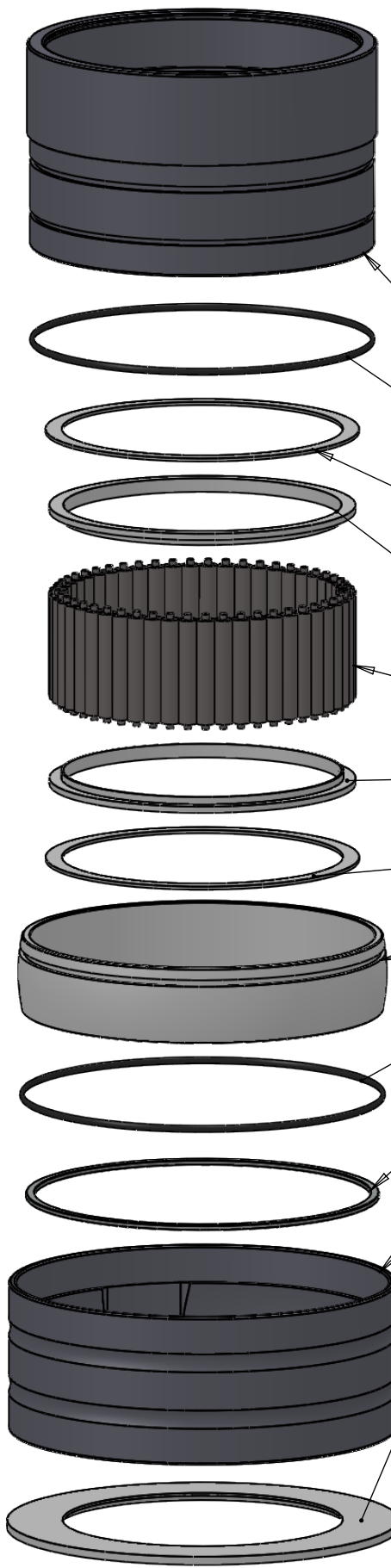

ITEM NO.	PART NUMBER	PART NAME	QTY.
1	M35-121	Inner house 4S140-4S149	1
2	O-ring	ø170 x 2,5	1
3	M03-305	Delrin Lockring ø168,5 x ø151 x 1,75mm	2
4	M05-344	L-ring ø149 ø151.5 ø165	2
5	M01-324	Roller ø9.5 x 57mm	51
6	M11-111	Ball 4S140-4S159	1
7	O-ring	ø180 x 2,5	1
8	M09-125	Alu lockring ø180.5 x ø189.5	1
9	M31-126	Outer house 4S140-4S159	1
10	M07-232-B	Washer, delrin ø150,5 x ø210 x 4,5mm	1

DWG NR / NAME:

4S146 / Self-aligning lower bearing

BATCH NR:

PROJECT:
Shaft Ø146mm, max working load 8800kg

REKV.NR / ORDRE NR:

DATE:
27-08-2009

NAME:
JR

SCALE / PAPER:
1:4 / A4

MATERIAL:
WEIGHT: g

LOCATION:
REV:

ORDRE DATO:

LEV.DATO:



JEFA MARINE A/S
NIMBUSVEJ 2
2670 GREVE, DENMARK

Tlf: +45 4615 5210 & Fax: +45 4615208
Email: info@jefa.com www.jefa.com

: /