

A

B

C

D

E

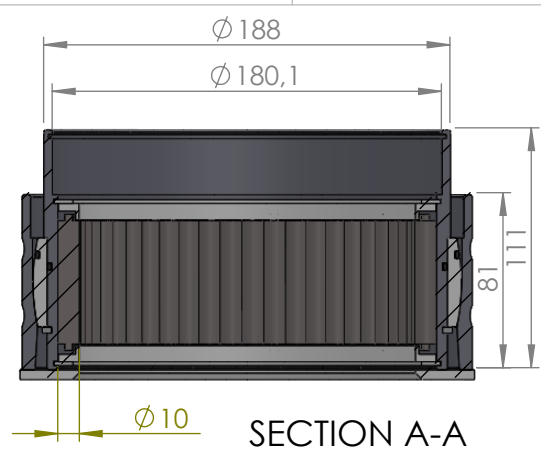

SECTION A-A
SCALE 1 : 3.5

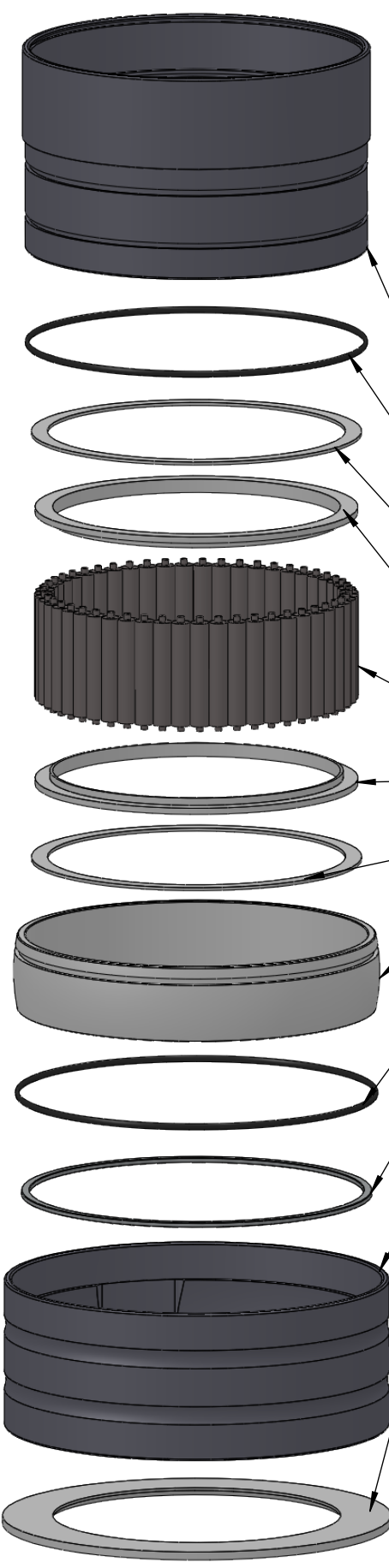
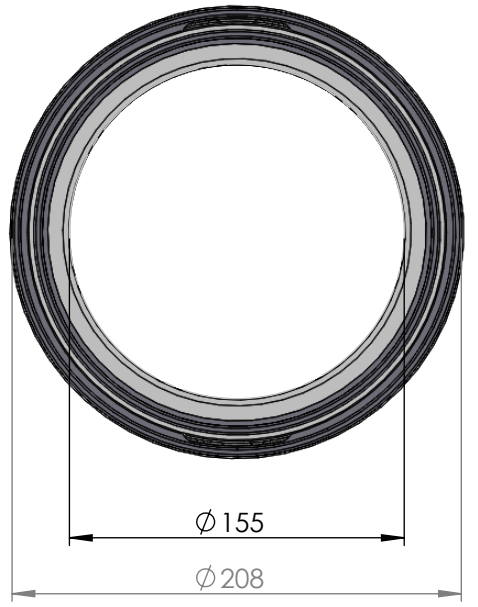
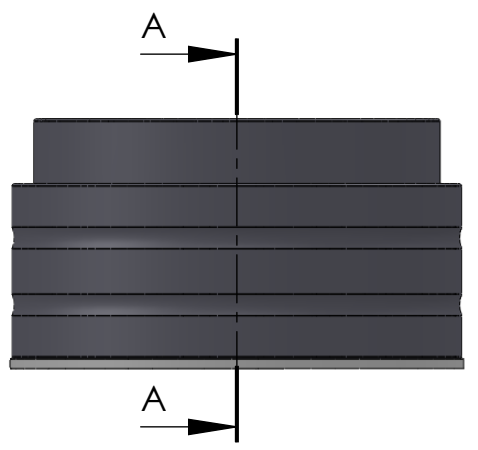

ITEM NO.	PART NUMBER	PART NAME	QTY
1	M35-123	Inner house 4S150-4S159	1
2	O-ring	ø170 x 2,5	1
3	M03-315	Delrin Lockring ø178,5 x ø161 x 1,75mm	2
4	M05-353	L-ring ø155 ø158 ø175	2
5	M01-332	Roller ø10.0 x 57mm	51
6	M11-111	Ball 4S140-4S159	1
7	O-ring	ø180 x 2,5	1
8	M09-125	Alu lockring ø180.5 x ø189.5	1
9	M31-126	Outer house 4S140-4S159	1
10	M07-232-D	Washer, delrin ø155,5 x ø210 x 4,5mm	1

DWG NR / NAME:

4S155 / Self-aligning lower bearing

BATCH NR:

PROJECT:
Shaft Ø155mm, max working load 9300kg

REKV.NR / ORDRE NR:

DATE:
27-08-2009

NAME:
JR

SCALE / PAPER:
1:4 / A4

MATERIAL:
WEIGHT: g

LOCATION:

ORDRE DATO:

MODIFY DATE:
: /

REV:

LEV.DATO:



JEFA MARINE A/S
NIMBUSVEJ 2
2670 GREVE, DENMARK

Tlf: +45 4615 5210 & Fax: +45 4615208
Email: info@jefa.com www.jefa.com