

SECTION A-A
SCALE 1 : 3.5

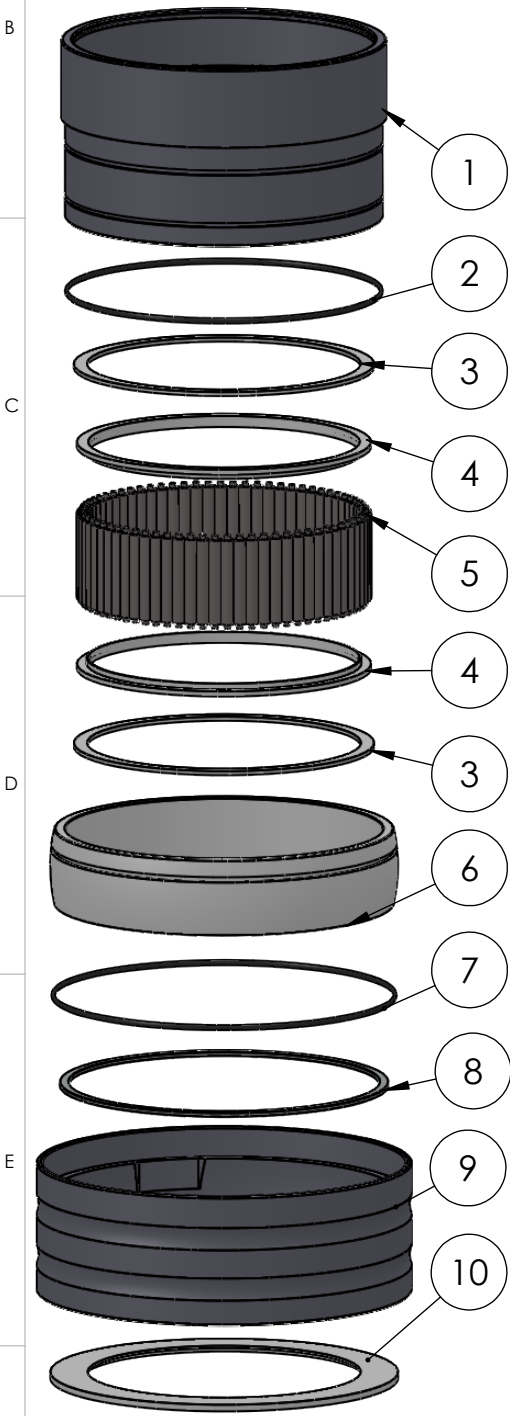
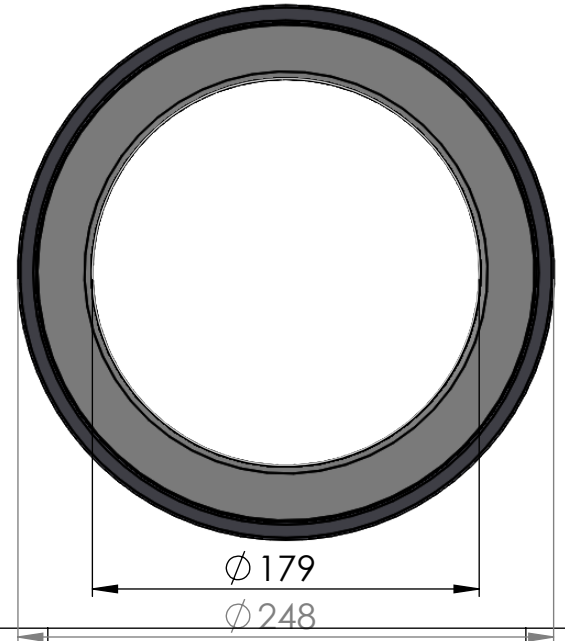
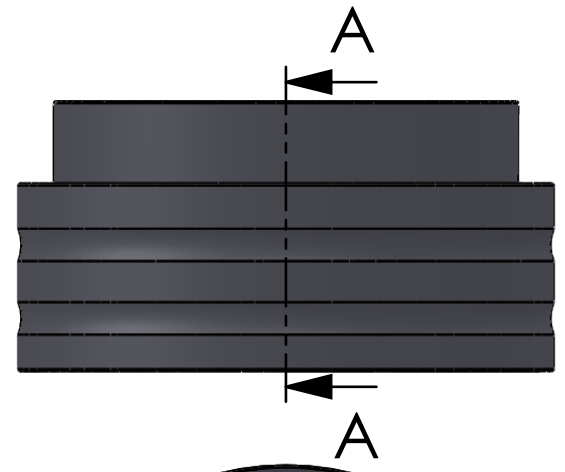

ITEM NO.	PART NUMBER	PART NAME	QTY.
1	M35-127	Inner house 4S170-4S179	1
2	O-ring	ø200 x 2.5	1
3	M03-735	Delrin Lockring ø198,5 x ø181 x 2,75mm	2
4	M05-379	L-ring ø179 ø182.5 ø195	2
5	M01-301	Roller ø8.0 x 57mm	72
6	M11-113	Ball 4S160-4S179	1
7	O-ring	ø210 x 2.5	1
8	M09-140	Alu lockring ø205 x ø217	1
9	M31-131	Outer house 4S160-4S179	1
10	M07-243	Washer ø179,5 x ø219 x 4,5	1

DWG NR / NAME:

4S179 / Self-aligning lower bearing

BATCH NR:

PROJECT:
Shaft Ø179mm, max working load 9700kg

REKV.NR / ORDRE NR:

DATE:
27-08-2009

NAME:
JR

SCALE / PAPER:
1:10 / A4

MATERIAL:
WEIGHT: g

LOCATION:
REV:

ORDRE DATO:

LEV.DATO:



JEFA MARINE A/S
NIMBUSVEJ 2
2670 GREVE, DENMARK

Tlf: +45 4615 5210 & Fax: +45 46155208
Email: info@jefa.com www.jefa.com

: /