

SECTION A-A  
SCALE 1 : 3.5

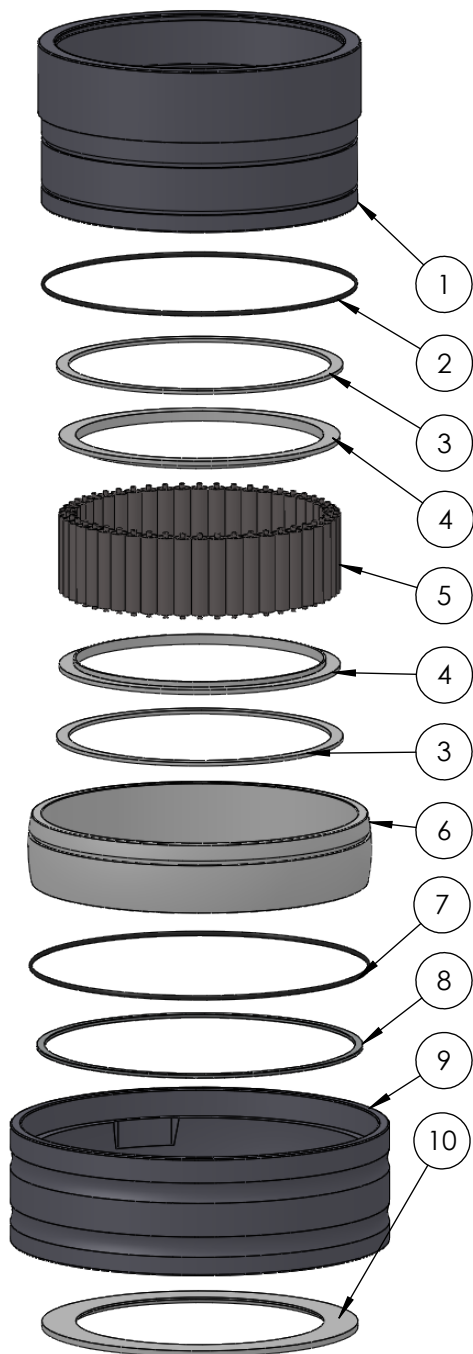
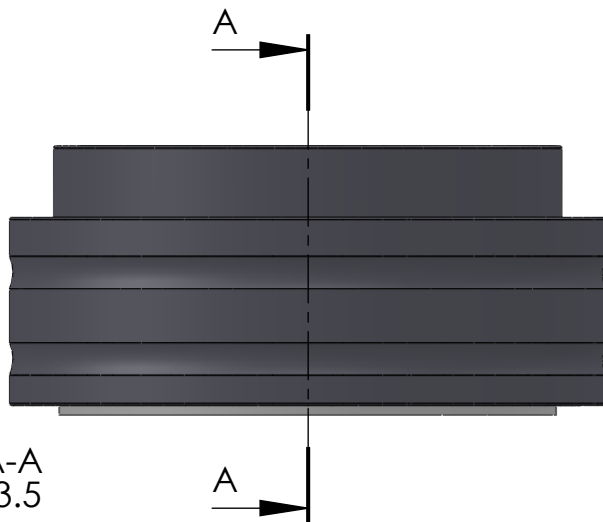

ITEM NO.	PART NUMBER	PART NAME	QTY
1	M35-129	Inner house 4S180-4S189	1
2	O-ring	ø220 x 2.5	1
3	M03-745	Delrin Lockring ø208,5 x ø191 x 2,75mm	2
4	M05-380	L-ring ø180 ø183.5 ø205	2
5	M01-372	Roller ø12.5 x 57mm	48
6	M11-115	Ball 4S180-4S199	1
7	O-ring	ø230 x 2.5	1
8	M09-150	Alu lockring ø225.5 x ø237.5	1
9	M31-136	Outer house 4S180-4S199	1
10	M07-245	Washer ø180,5 x ø230 x 4,5	1

DWG NR / NAME:

## 4S180 / Self-aligning lower bearing

BATCH NR:

PROJECT:

Shaft Ø180mm, max working load 10300kg

REKV.NR / ORDRE NR:

DATE:

27-08-2009

NAME:

JR

SCALE / PAPER:

1:5 / A4

MATERIAL:

WEIGHT:

g

LOCATION:

REV:

ORDRE DATO:

LEV.DATO:

MODIFY DATE:

: /

*Jefa Rudder*  
SYSTEMS

JEFA MARINE A/S  
NIMBUSVEJ 2  
2670 GREVE, DENMARK

Tlf: +45 4615 5210 & Fax: +45 46155208  
Email: info@jefa.com www.jefa.com