

SECTION A-A
SCALE 1 : 3.5

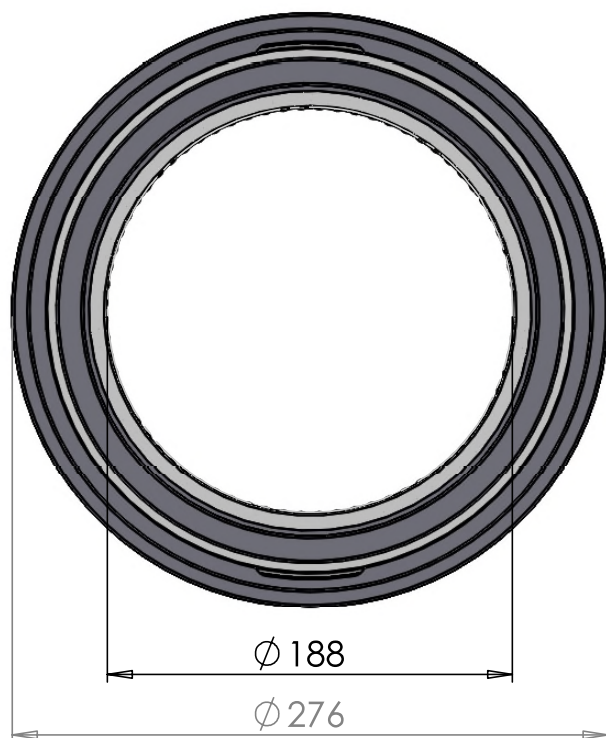
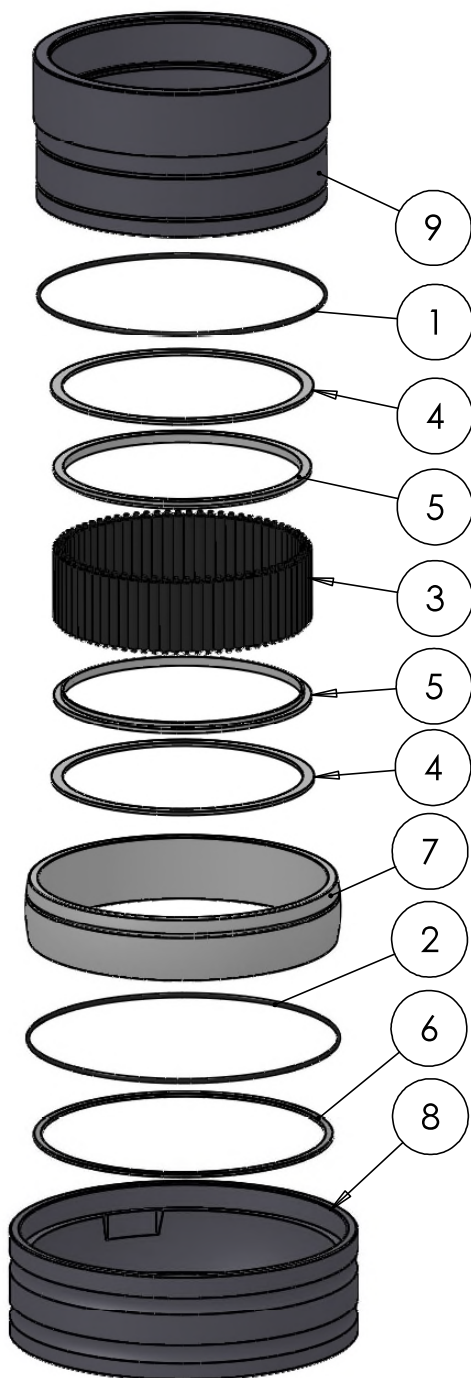
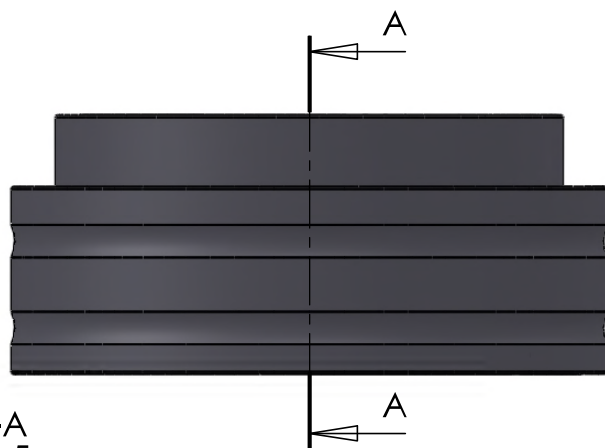

ITEM NO.	PART NUMBER	PART NAME	QTY.
1	O-ring	$\varnothing 200 \times 2.5$	1
2	O-ring	$\varnothing 220 \times 2.5$	1
3	M01-308	Roller $\varnothing 8.5 \times 57\text{mm}$	72
4	M03-745	Delrin Lockring $\varnothing 208,5 \times \varnothing 191 \times 2,75\text{mm}$	2
5	M05-381	L-ring $\varnothing 189 \times \varnothing 205 \times 7,5\text{mm}$	2
6	M09-150	Alu lockring $\varnothing 225.5 \times \varnothing 237.5$	1
7	M11-115	Ball 4S180-4S199	1
8	M31-136	Outer house 4S180-4S199	1
9	M35-129	Inner house 4S180-4S189	1

DWG NR / NAME:

4S188 / Self-aligning lower bearing

BATCH NR:

PROJECT:

Shaft $\varnothing 188\text{mm}$, max working load 10300 kg

REKV.NR / ORDRE NR:

DATE:
28-09-2009

NAME:
JR

SCALE / PAPER:
1:6 / A4

MATERIAL:
WEIGHT: g

LOCATION:

ORDRE DATO:

MODIFY DATE:
24-08-2023

REV:

LEV.DATO:

Jefa Rudder
SYSTEMS

JEFA MARINE A/S
NIMBUSVEJ 2
2670 GREVE, DENMARK
Tlf: +45 4615 5210
E-mail: info@jefa.dk https://jefa.dk