

SECTION A-A  
SCALE 1 : 3.5

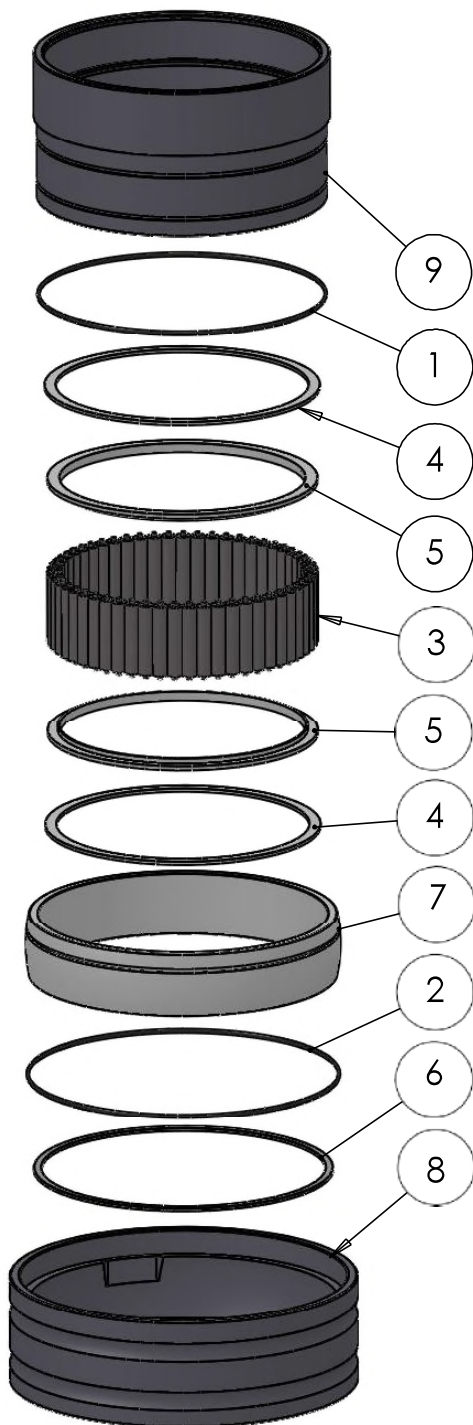

ITEM NO.	PART NUMBER	PART NAME	QTY.
1	O-ring	$\phi 200 \times 2.5$	1
2	O-ring	$\phi 220 \times 2.5$	1
3	M01-356	Roller $\phi 11.5 \times 57\text{mm}$	55
4	M03-755	Delrin Lockring $\phi 218.5 \times \phi 201 \times 2.75\text{mm}$	2
5	M05-382-B	L-ring $\phi 195 \times \phi 215 \times 7.5\text{mm}$	2
6	M09-150	Alu lockring $\phi 225.5 \times \phi 237.5$	1
7	M11-115	Ball 4S180-4S199	1
8	M31-136	Outer house 4S180-4S199	1
9	M35-131	Inner house 4S190-4S199	1

DWG-NR / NAME:

## 4S192 / Self-aligning lower bearing

BATCH NR:

PROJECT:

Shaft  $\phi 192\text{mm}$ , max working load 10800 kg

REKV.NR / ORDRE NR:

DATE:

28-09-2009

NAME:

JR

SCALE / PAPER:

1:6 / A4

MATERIAL:

WEIGHT:

g

LOCATION:

REV:

ORDRE DATO:

LEV.DATO:

MODIFY DATE:

24-08-2023

*Jefa Rudder*  
SYSTEMS

JEFA MARINE A/S  
NIMBUSVEJ 2  
2670 GREVE, DENMARK  
Tlf: +45 4615 5210  
E-mail: info@jefa.dk https://jefa.dk