

SECTION A-A  
SCALE 1 : 5

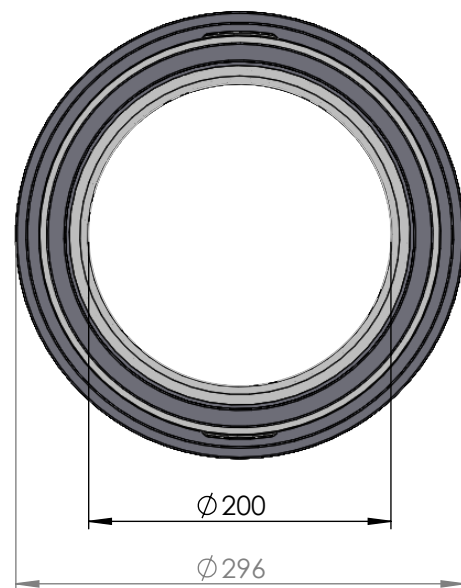
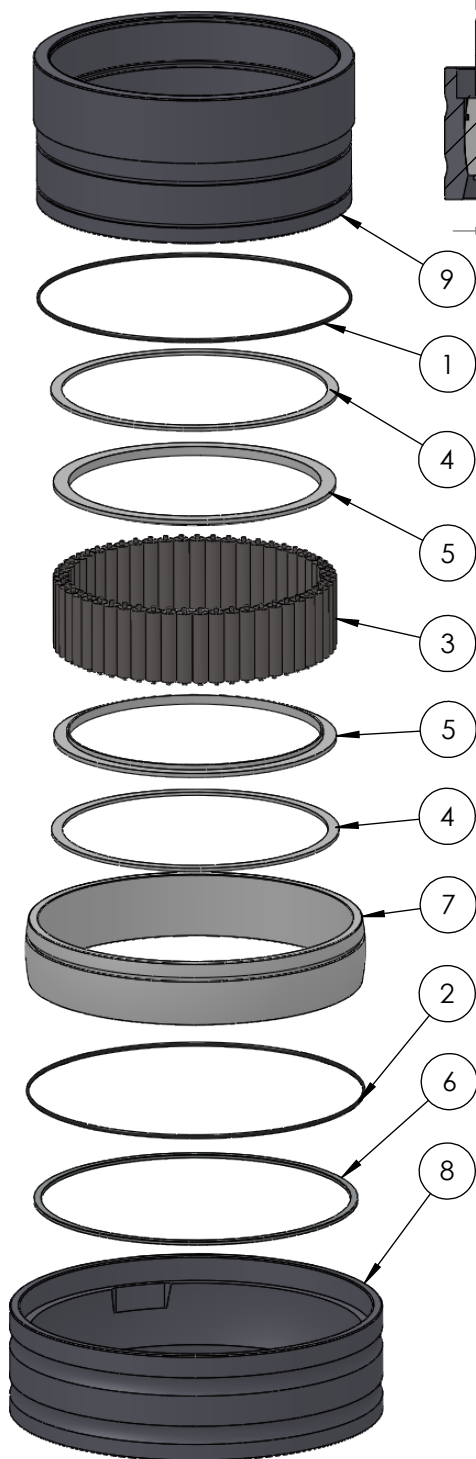

ITEM NO.	PART NUMBER	PART NAME	QTY
1	O-ring	ø240 x 2.5	1
2	O-ring	ø250 x 2.5	1
3	M01-372	Roller ø12.5 x 57mm	53
4	M03-765	Delrin Lockring ø228,5 x ø211 x 2,75mm	2
5	M05-386	L-ring ø200 ø225 x 7,5mm	2
6	M09-160	Alu lockring ø246 x ø257	1
7	M11-117	Ball 4S200-4S219	1
8	M31-141	Outer house 4S200-4S219	1
9	M35-133	Inner house 4S200-4S209	1

DWG NR / NAME:

**4S200 / Self-aligning lower bearing**

BATCH NR:

PROJECT:

Shaft ø200mm, max working load 11400 kg

REKV.NR / ORDRE NR:

DATE:

01-10-2009

NAME:

JR

SCALE / PAPER:

1:6 / A4

MATERIAL:

WEIGHT: g

LOCATION:

ORDRE DATO:

MODIFY DATE:

: /

REV:

LEV.DATO:

*Jefa Rudder*  
SYSTEMS

JEFA MARINE A/S  
NIMBUSVEJ 2  
2670 GREVE, DENMARK

Tlf: +45 4615 5210 & Fax: +45 4615208  
Email: info@jefa.com www.jefa.com