

SECTION A-A
SCALE 1 : 5

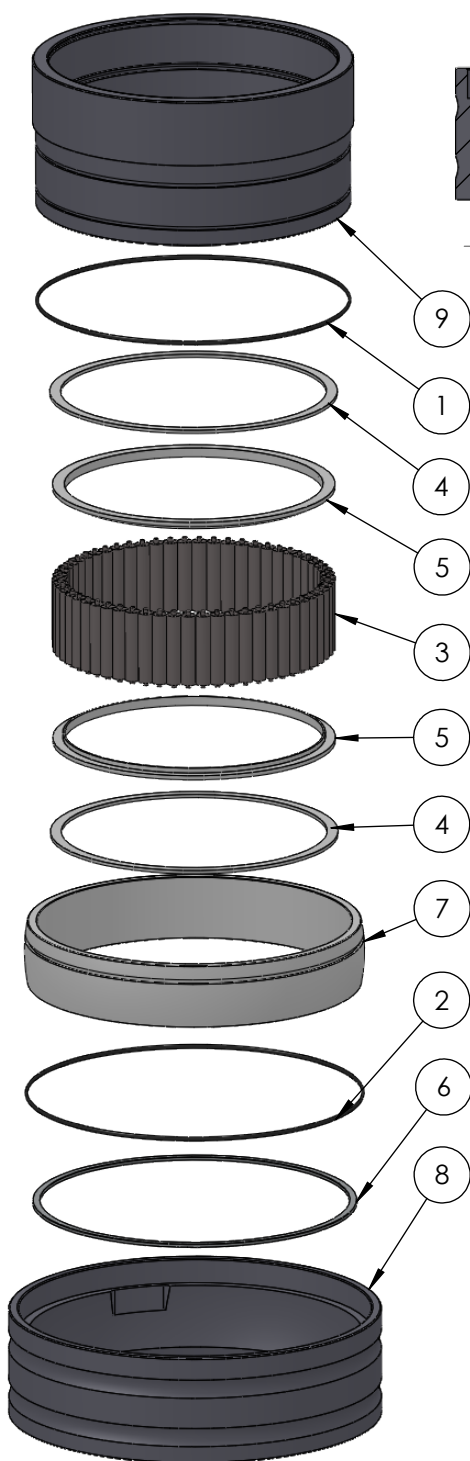
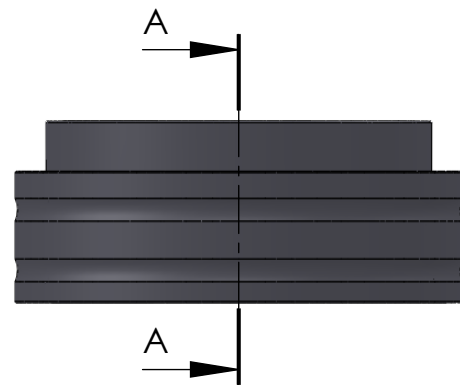

ITEM NO.	PART NUMBER	PART NAME	QTY
1	O-ring	ø240 x 2.5	1
2	O-ring	ø250 x 2.5	1
3	M01-356	Roller ø11.5 x 57mm	58
4	M03-765	Delrin Lockring ø228,5 x ø211 x 2,75mm	2
5	M05-387	L-ring ø205 x ø225 x 7,5mm	2
6	M09-160	Alu lockring ø246 x ø258	1
7	M11-117	Ball 4S200-4S219	1
8	M31-141	Outer house 4S200-4S219	1
9	M35-1313	Inner house 4S200-4S209	1

DWG NR / NAME:

4S202 / Self-aligning lower bearing

BATCH NR:

PROJECT:

Shaft ø202mm, max working load 11400 kg

REKV.NR / ORDRE NR:

DATE:

07-10-2009

NAME:

JR

SCALE / PAPER:

1:6 / A4

MATERIAL:

WEIGHT:

g

LOCATION:

REV:

ORDRE DATO:

LEV.DATO:

Jefa Rudder
SYSTEMS

JEFA MARINE A/S
NIMBUSVEJ 2
2670 GREVE. DENMARK

Tlf: +45 4615 5210 & Fax: +45 46155208
Email: info@jefa.com www.jefa.com

: /