

SECTION A-A
SCALE 1 : 3.5

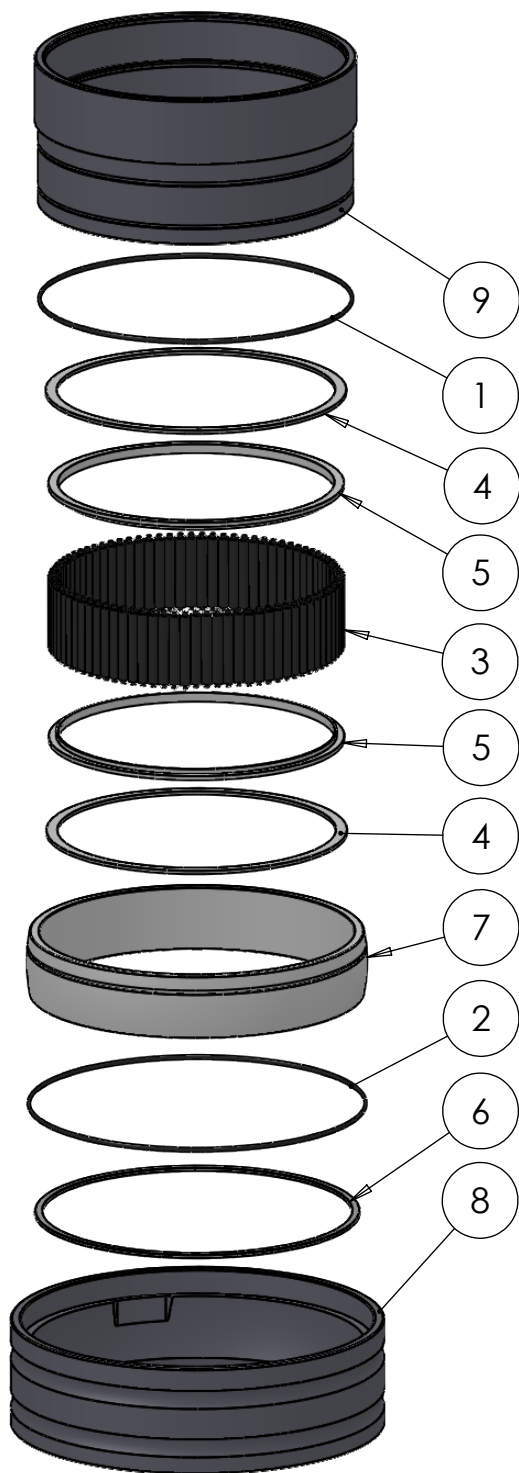
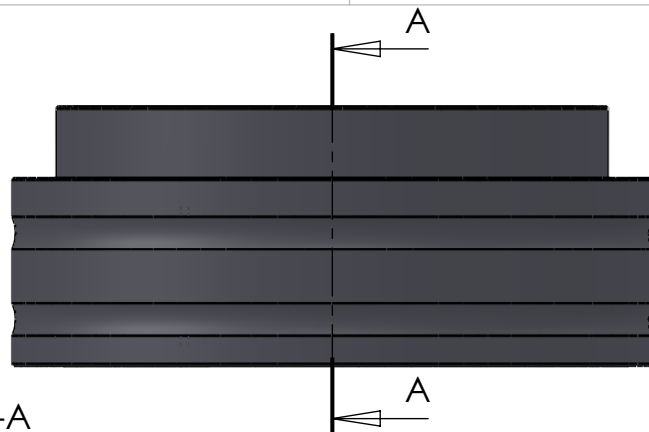

ITEM NO.	PART NUMBER	PART NAME	QTY.
1	O-ring	$\phi 240 \times 2.5$	1
2	O-ring	$\phi 250 \times 2.5$	1
3	M01-308	Roller $\phi 8.5 \times 57\text{mm}$	83
4	M03-775	Delrin Lockring $\phi 238,5 \times \phi 221 \times 2,75\text{mm}$	2
5	M05-389-A	L-ring $\phi 219 \phi 235 \times 7,5\text{mm}$	2
6	M09-160	Alu lockring $\phi 246 \times \phi 258$	1
7	M11-117	Ball 4S200-4S219	1
8	M31-141	Outer house 4S200-4S219	1
9	M35-135	Inner house 4S210-4S219	1

DWG NR / NAME:

4S218 / Self-aligning lower bearing

BATCH NR:

PROJECT:

Shaft $\phi 218\text{mm}$, max working load 12000 kg

REKV.NR / ORDRE NR:

DATE:

28-09-2009

NAME:

JR

SCALE / PAPER:

1:6 / A4

MATERIAL:

WEIGHT:

g

LOCATION:

REV:

ORDRE DATO:

LEV.DATO:

MODIFY DATE:

: /

Jefa Rudder
SYSTEMS

JEFA MARINE A/S
NIMBUSVEJ 2
2670 GREVE, DENMARK

Tlf: +45 4615 5210 & Fax: +45 4615 5208
Email: info@jefa.com www.jefa.com