

SECTION A-A
SCALE 1 : 4

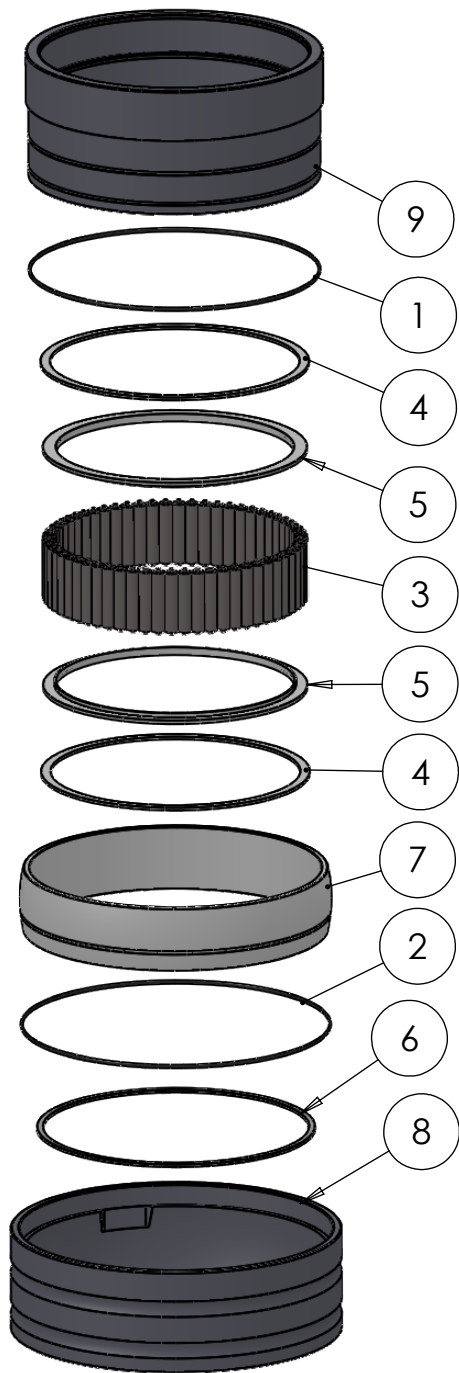
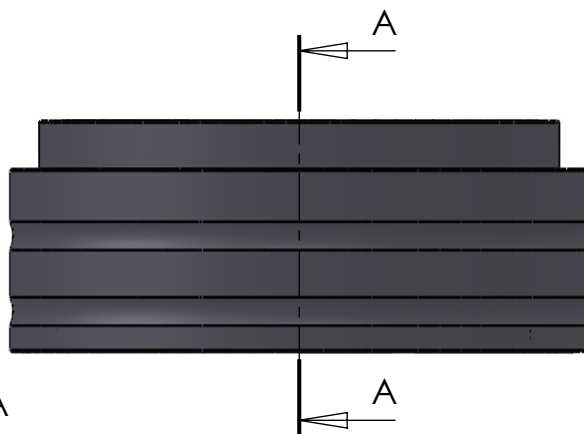

ITEM NO.	PART NUMBER	PART NAME	QTY.
1	O-ring	$\phi 260 \times 2.5$	1
2	O-ring	$\phi 270 \times 2.5$	1
3	M01-364	Roller $\phi 12.0 \times 57\text{mm}$	60
4	M03-785	Delrin Lockring $\phi 248,5 \times \phi 231 \times 2,75\text{mm}$	2
5	M05-395	L-ring $\phi 225 \phi 245 \times 7,5\text{mm}$	2
6	M09-170	Alu lockring $\phi 266 \times \phi 278$	1
7	M11-119	Ball 4S220-4S239	1
8	M31-146	Outer house 4S220-4S239	1
9	M35-137	Inner house 4S220-4S229	1

DWG NR / NAME:

4S221 / Self-aligning lower bearing

BATCH NR:

PROJECT:

Shaft $\phi 221\text{mm}$, max working load 12500 kg

REKV.NR / ORDRE NR:

DATE:

28-09-2009

NAME:

JR

SCALE / PAPER:

1:7 / A4

MATERIAL:

WEIGHT:

g

LOCATION:

REV:

ORDRE DATO:

LEV.DATO:

Jefa Rudder
SYSTEMS

JEFA MARINE A/S
NIMBUSVEJ 2
2670 GREVE, DENMARK

Tlf: +45 4615 5210 & Fax: +45 46155208
Email: info@jefa.com www.jefa.com

: /