

SECTION A-A

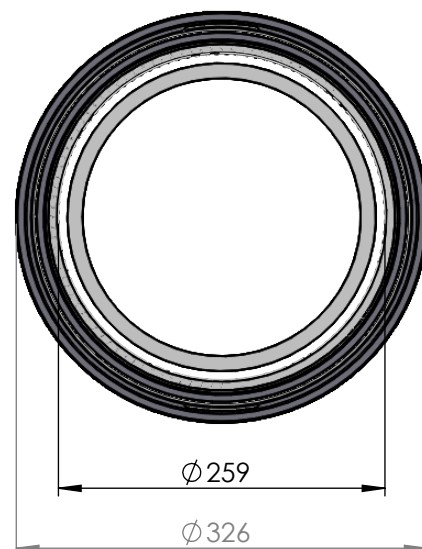
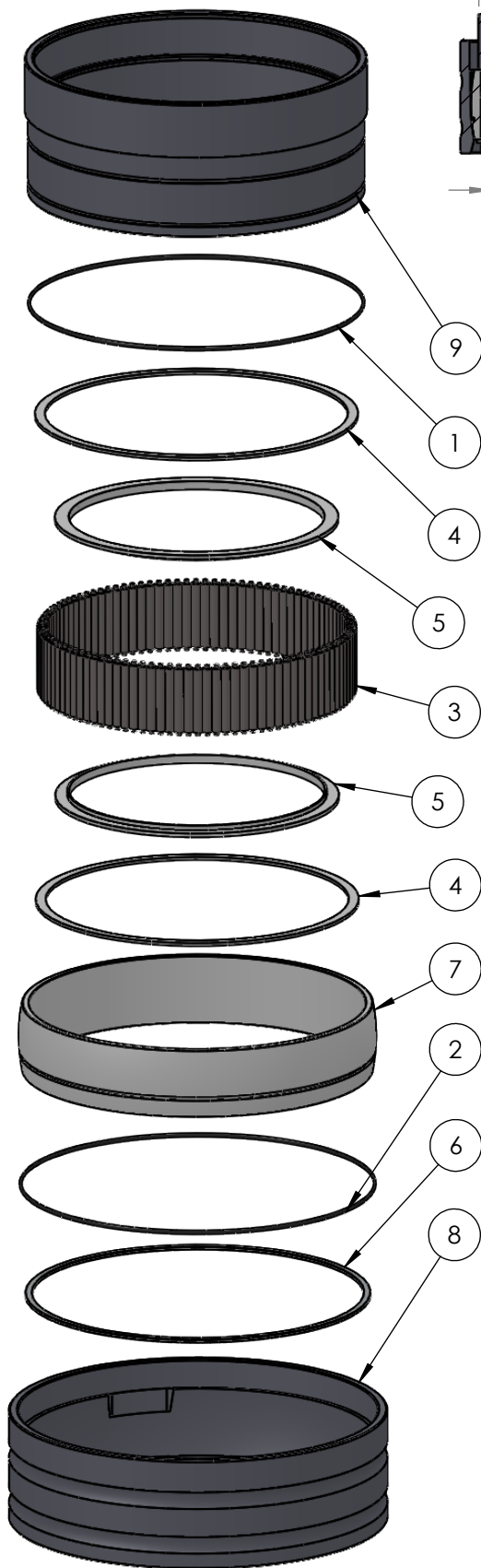
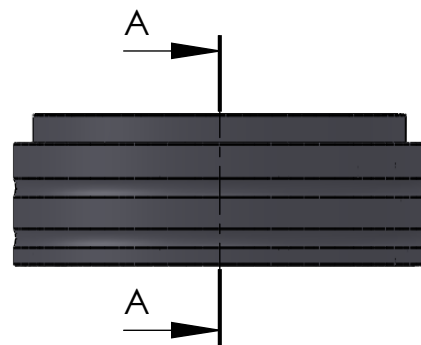

ITEM NO.	PART NUMBER	PART NAME	QTY
1	O-ring	ø280 x 2.5	1
2	O-ring	ø290 x 2.5	1
3	M01-301	Roller ø8.0 x 57mm	104
4	M03-815	Delrin Lockring ø278,5 x ø261 x 2,75mm	2
5	M05-421	L-ring ø260 ø275 x 7,5mm	2
6	M09-180	Alu lockring ø285 x ø297 x 2,75	1
7	M11-121	Ball 4S240-4S259	1
8	M31-151	Outer house 4S240-4S259	1
9	M35-143	Inner house 4S250-4S259	1

DWG NR / NAME:

4S259 / Self-aligning lower bearing

BATCH NR:

PROJECT:

Shaft ø259mm, max working load 14200 kg

REKV.NR / ORDRE NR:

DATE:

08-10-2009

NAME:

JR

SCALE / PAPER:

1:6 / A4

MATERIAL:

WEIGHT:

g

LOCATION:

REV:

ORDRE DATO:

LEV.DATO:

MODIFY DATE:

: /

Jefa Rudder
SYSTEMS

JEFA MARINE A/S
NIMBUSVEJ 2
2670 GREVE, DENMARK

Tlf: +45 4615 5210 & Fax: +45 4615 5208
Email: info@jefa.com www.jefa.com