

SECTION A-A  
SCALE 1 : 2

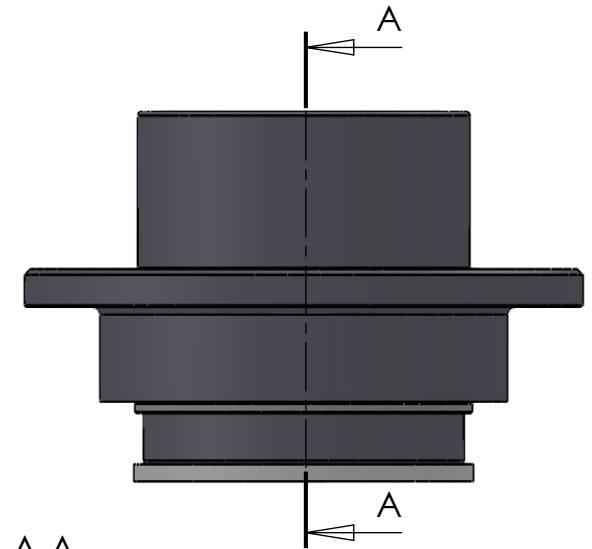

ITEM NO.	PART NUMBER	PART NAME	QTY.
1	M33-101	Outer house 4SF040-4SF059	1
2	M11-101	Ball 4SF040-4SF059	1
3	O-ring	ø90 x 2,5	1
4	M03-195	Delrin Lockring ø68,5 x ø51 x 1,75mm	2
5	M05-113	L-ring ø40 ø43.5 ø65	2
6	M01-272	Roller ø12.5 x 44mm	13
7	M35-101	Inner house 4SF040-4SF049	1
8	O-ring	ø75 x 2,5mm	1
9	M09-101	Alu lockring ø80.5 x ø89.5	1
10	M07-107-B	Washer, delrin ø40,5 x ø90 x 4,5mm	1

DWG NR / NAME:

### 4SF040 / S-A top roller bearing

BATCH NR:

PROJECT:

Shaft ø40mm. Max working load 2100kg

REKV.NR / ORDRE NR:

DATE:

20-01-2011

NAME:

JR

SCALE / PAPER:

1:2.5/ A4

MATERIAL:

WEIGHT: g

LOCATION:

ORDRE DATO:

MODIFY DATE:

: /

REV:

LEV.DATO:

*Jefa Rudder*  
S Y S T E M S

JEFA MARINE A/S  
NIMBUSVEJ 2  
2670 GREVE. DENMARK

Tlf: +45 4615 5210 & Fax: +45 46155208  
Email: info@jefa.com www.jefa.com