

SECTION A-A
SCALE 1 : 2

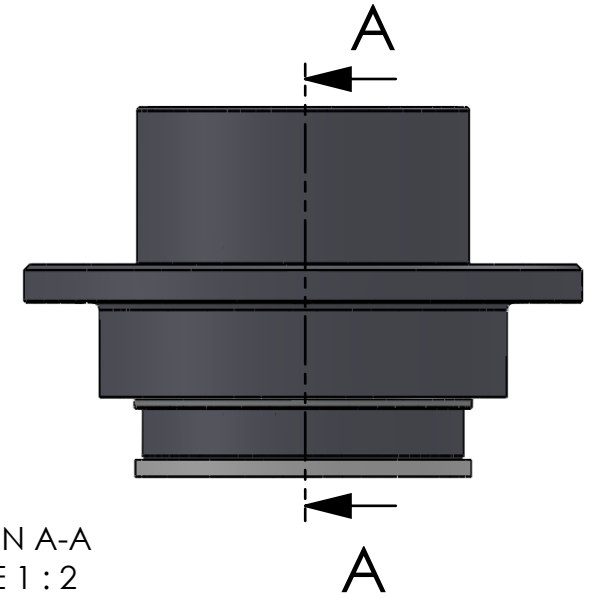

ITEM NO.	PART NUMBER	PART NAME	QTY.
1	M33-101	Outer house 4SF040-4SF059	1
2	M11-101	Ball 4SF040-4SF059	1
3	O-ring	ø90 x 2,5	1
4	M03-201	Delrin Lockring ø78,5 x ø61 x 1,75mm	2
5	M05-137	L-ring ø53 x ø56.5 ø75	2
6	M01-248	Roller ø11 x 44mm	18
7	M35-103	Inner house 4SF050-4SF059	1
8	O-ring	ø75 x 2,5mm	1
9	M09-101	Alu lockring ø80.5 x ø89.5	1
10	M07-119	Washer ø53.5 ø89	1

DWG NR / NAME:

4SF053 / S-A top roller bearing

BATCH NR:

PROJECT:

Shaft Ø53mm, max working load 2600kg

REKV.NR / ORDRE NR:

DATE:

20-01-2011

NAME:

JR

SCALE / PAPER:

1:10 / A4

MATERIAL:

WEIGHT: g

LOCATION:

REV:

ORDRE DATO:

LEV.DATO:

MODIFY DATE:

: /

Jefa Rudder
SYSTEMS

JEFA MARINE A/S
NIMBUSVEJ 2
2670 GREVE, DENMARK

Tlf: +45 4615 5210 & Fax: +45 46155208
Email: info@jefa.com www.jefa.com