

SECTION A-A
SCALE 1 : 2.5

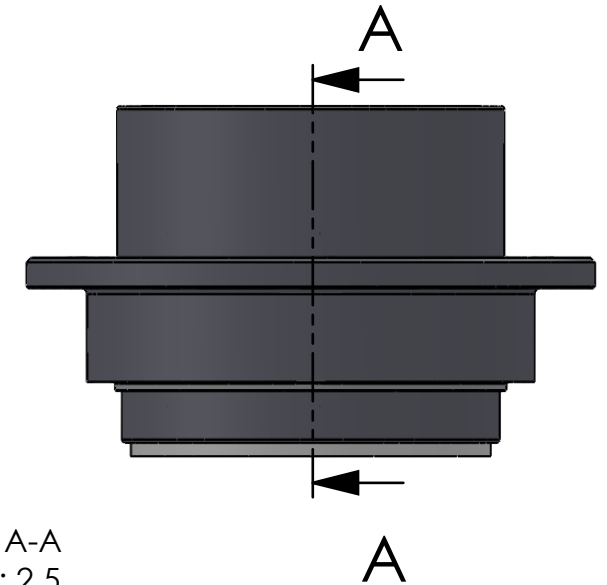

ITEM NO.	PART NUMBER	PART NAME	QTY.
1	M33-110	Outer house 4SF080-4SF099	1
2	M11-105	Ball 4SF080-4SF099	1
3	O-ring	ø120 x 2.5mm	1
4	M03-220	Delrin Lockring ø108,5 x ø91 x 1,75mm	2
5	M05-194	L-ring, delrin ø84 x ø105 x 7,5mm	2
6	M01-364	Roller ø12.0 x 57mm	24
7	M35-109	Inner house 4SF080-4SF089	1
8	O-ring	ø115 x 2.5	1
9	M09-110	Alu lockring ø120.5 x ø129.5	1
10	M07-162	Washer, delrin ø82,5 x ø119 x 4,5mm	1

DWG NR / NAME:

4SF081 / S-A top roller bearing

BATCH NR:

PROJECT:

Shaft Ø81mm, max working load 5600kg

REKV.NR / ORDRE NR:

DATE:

20-01-2011

NAME:

JR

SCALE / PAPER:

1:10 / A4

MATERIAL:

WEIGHT: g

LOCATION:

ORDRE DATO:

MODIFY DATE:

: /

REV:

LEV.DATO:

Jefa Rudder
SYSTEMS

JEFA MARINE A/S
NIMBUSVEJ 2
2670 GREVE. DENMARK
Tlf: +45 4615 5210 & Fax: +45 46155208
Email: info@jefa.com www.jefa.com