

SECTION A-A  
SCALE 1 : 2.5

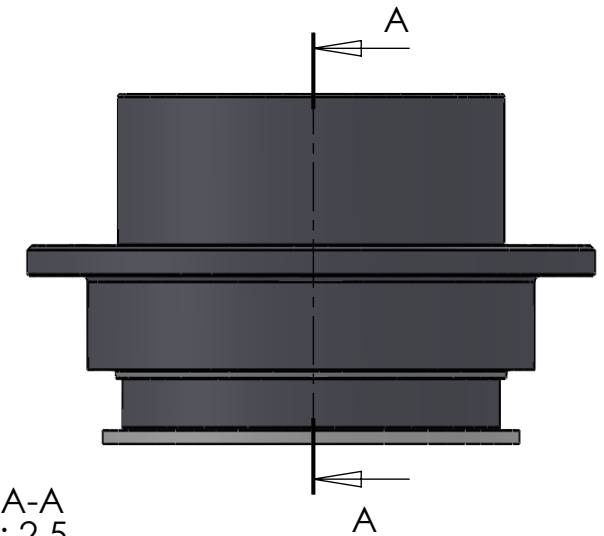

ITEM NO.	PART NUMBER	PART NAME	QTY.
1	M33-110	Outer house 4SF080-4SF099	1
2	M11-105	Ball 4SF080-4SF099	1
3	O-ring	ø120 x 2.5mm	1
4	M03-228	Delrin Lockring ø118,5 x 101 x 1,75mm	2
5	M05-221	L-ring ø95 ø98.5 ø115	2
6	M01-332	Roller ø10.0 x 57mm	33
7	M35-111	Inner house 4SF090-4SF099	1
8	O-ring	ø115 x 2.5	1
9	M09-110	Alu lockring ø120.5 x ø129.5	1
10	M07-179	Washer ø95.5 ø138	1

DWG NR / NAME: <b>4SF095 / S-A Top roller bearing</b>				BATCH NR:		<i>Jefa Rudder</i> S Y S T E M S
PROJECT: Shaft Ø95mm, max working load 6200kg				REKV.NR / ORDRE NR:		
DATE: 20-01-2011	NAME: JR	SCALE / PAPER: 1:3.5 / A4	MATERIAL: WEIGHT: g	LOCATION:	ORDRE DATO:	JEFA MARINE A/S NIMBUSVEJ 2 2670 GREVE. DENMARK Tlf: +45 4615 5210 & Fax: +45 46155208 Email: info@jefa.com www.jefa.com
MODIFY DATE: : /				REV:	LEV.DATO:	