

SECTION A-A  
SCALE 1 : 3

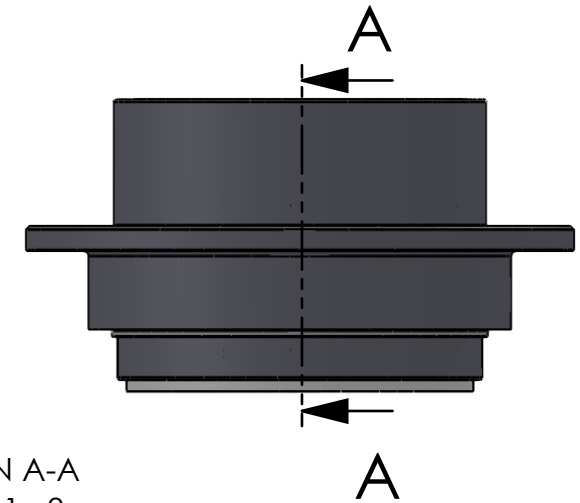

ITEM NO.	PART NUMBER	PART NAME	QTY.
1	M33-115	Outer house 4SF100-4SF119	1
2	M11-107	Ball 4SF100-4SF119	1
3	O-ring	$\varnothing 140 \times 2.5\text{mm}$	1
4	M03-235	Delrin Lockring $\varnothing 128,5 \times \varnothing 111 \times 1,75\text{mm}$	2
5	M05-257	L-ring $\varnothing 105 \varnothing 108.5 \varnothing 125$	2
6	M01-364	Roller $\varnothing 12.0 \times 57\text{mm}$	29
7	M35-113	Inner house 4SF100-4SF109	1
8	O-ring	$\varnothing 130 \times 2.5\text{mm}$	1
9	M09-115	Alu lockring $\varnothing 140.5 \times \varnothing 149.5$	1
10	M07-188	Washer $\varnothing 104.5 \varnothing 138$	1

DWG NR / NAME:

### 4SF101 / S-A top roller bearing

BATCH NR:

PROJECT:

Shaft  $\varnothing 101\text{mm}$ , max working load 6800kg

REKV.NR / ORDRE NR:

DATE:

20-01-2011

NAME:

JR

SCALE / PAPER:

1:10 / A4

MATERIAL:

WEIGHT: g

LOCATION:

REV:

ORDRE DATO:

LEV.DATO:

MODIFY DATE:

: /

*Jefa Rudder*  
SYSTEMS

JEFA MARINE A/S  
NIMBUSVEJ 2  
2670 GREVE. DENMARK

Tlf: +45 4615 5210 & Fax: +45 46155208  
Email: info@jefa.com www.jefa.com