

SECTION A-A
SCALE 1 : 3

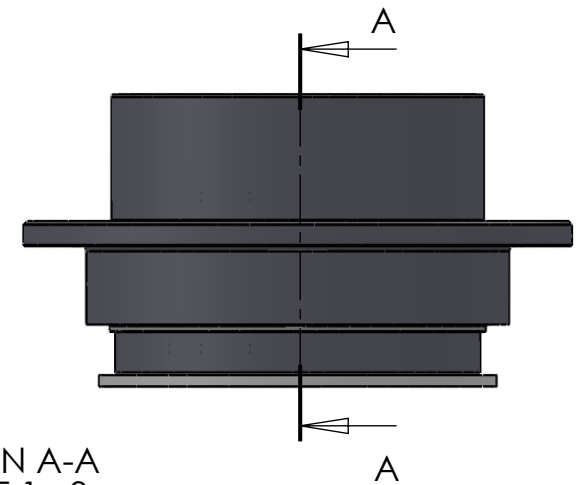

ITEM NO.	PART NUMBER	PART NAME	QTY.
1	M33-115	Outer house 4SF100-4SF119	1
2	M11-107	Ball 4SF100-4SF119	1
3	O-ring	$\varnothing 140 \times 2.5\text{mm}$	1
4	M03-275	Delrin Lockring $\varnothing 138,5 \times \varnothing 121 \times 1,75\text{mm}$	2
5	M05-287	L-ring $\varnothing 119 \varnothing 121.5 \varnothing 135$	2
6	M01-308	Roller $\varnothing 8.5 \times 57\text{mm}$	46
7	M35-115	Inner house 4SF110-4SF119	1
8	O-ring	$\varnothing 130 \times 2.5\text{mm}$	1
9	M09-115	Alu lockring $\varnothing 140.5 \times \varnothing 149.5$	1
10	M07-206	Washer $\varnothing 119.5 \varnothing 158$	1

DWG NR / NAME: 4SF118 / S-A top roller bearing				BATCH NR:		<i>Jefa Rudder</i> S Y S T E M S
PROJECT: Shaft $\varnothing 118\text{mm}$, max working load 7300kg				REKV.NR / ORDRE NR:		
DATE: 20-01-2011	NAME: JR	SCALE / PAPER: 1:4 / A4	MATERIAL: WEIGHT: g	LOCATION:	ORDRE DATO:	JEFA MARINE A/S NIMBUSVEJ 2 2670 GREVE. DENMARK Tlf: +45 4615 5210 & Fax: +45 46155208 Email: info@jefa.com www.jefa.com
MODIFY DATE: : /				REV:	LEV.DATO:	