

SECTION A-A
SCALE 1 : 3

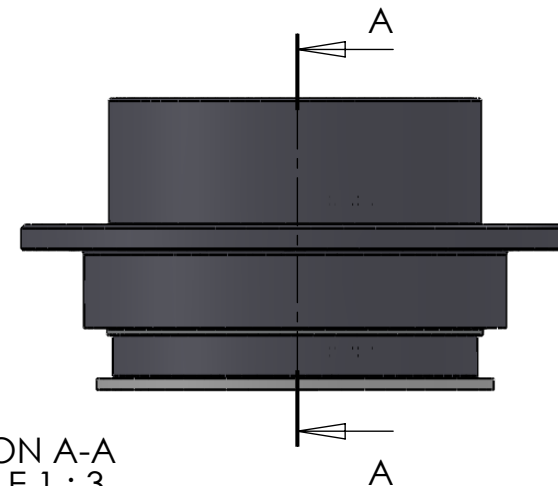

ITEM NO.	PART NUMBER	PART NAME	QTY.
1	M33-115	Outer house 4SF100-4SF119	1
2	M11-107	Ball 4SF100-4SF119	1
3	O-ring	ø140 x 2.5mm	1
4	M03-275	Delrin Lockring ø138,5 x ø121 x 1,75mm	2
5	M05-287	L-ring ø119 ø121.5 ø135	2
6	M01-301	Roller ø8.0 x 57mm	50
7	M35-115	Inner house 4SF110-4SF119	1
8	O-ring	ø130 x 2.5mm	1
9	M09-115	Alu lockring ø140.5 x ø149.5	1
10	M07-206	Washer ø119.5 ø158	1

DWG NR / NAME: 4SF119 / S-A top roller bearing				BATCH NR:		<i>Jefa Rudder</i> S Y S T E M S
PROJECT: Shaft Ø119mm, max working load 7300kg				REKV.NR / ORDRE NR:		
DATE: 20-01-2011	NAME: JR	SCALE / PAPER: 1:4 / A4	MATERIAL: g	LOCATION:	ORDRE DATO:	JEFA MARINE A/S NIMBUSVEJ 2 2670 GREVE. DENMARK Tlf: +45 4615 5210 & Fax: +45 46155208 Email: info@jefa.com www.jefa.com
MODIFY DATE: : /				REV:	LEV.DATO:	