

SECTION A-A  
SCALE 1 : 3

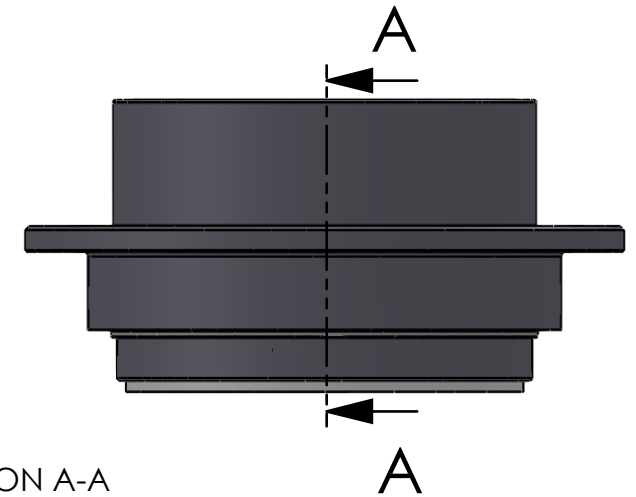

ITEM NO.	PART NUMBER	PART NAME	QTY.
1	M33-120	Outer house 4SF120-4SF139	1
2	M11-109	Ball 4SF120-4SF139	1
3	O-ring	ø160 x 2.5mm	1
4	M03-285	Delrin Lockring ø148,5 x ø131 x 1,75mm	2
5	M05-296	L-ring ø123 ø126.5 ø145	2
6	M01-348	Roller ø11.0 x 57mm	38
7	M35-117	Inner house 4SF120-4SF129	1
8	O-ring	ø150 x 2.5mm	1
9	M09-120	Alu lockring ø160.5 x ø169.5	1
10	M07-212	Washer ø124.5 ø158	1

DWG NR / NAME:

### 4SF123 / S-A top roller bearing

BATCH NR:

PROJECT:

Shaft Ø123mm, max working load 7900kg

REKV.NR / ORDRE NR:

DATE:

20-01-2011

NAME:

JR

SCALE / PAPER:

1:10 / A4

MATERIAL:

WEIGHT: g

LOCATION:

ORDRE DATO:

MODIFY DATE:

: /

REV:

LEV.DATO:

*Jefa Rudder*  
SYSTEMS

JEFA MARINE A/S  
NIMBUSVEJ 2  
2670 GREVE, DENMARK  
Tlf: +45 4615 5210 & Fax: +45 46155208  
Email: info@jefa.com www.jefa.com