

SECTION A-A  
SCALE 1 : 4

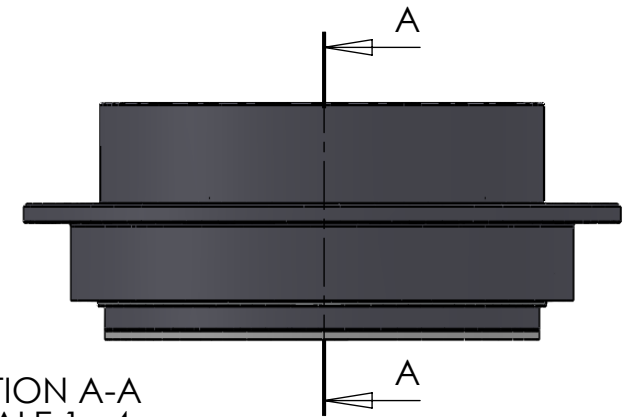

ITEM NO.	PART NUMBER	PART NAME	QTY.
1	M33-135	Outer house 4SF180-4SF199	1
2	M11-115	Ball 4SF180-4SF199	1
3	O-ring	ø230 x 2.5	1
4	M03-745	Delrin Lockring ø208,5 x ø191 x 2,75mm	2
5	M05-380	L-ring ø180 ø183.5 ø205	2
6	M01-372	Roller ø12.5 x 57mm	48
7	M35-129	Inner house 4SF180-4SF189	1
8	O-ring	ø220 x 2.5	1
9	M09-150	Alu lockring ø225.5 x ø237.5	1
10	M07-245	Washer ø180,5 x ø230 x 4,5	1

DWG NR / NAME: **4SF180 / S-A top roller bearing**

PROJECT: Shaft Ø180mm, max working load 10300kg

DATE: 20-01-2011

NAME: JR

SCALE / PAPER: 1:6 / A4

MATERIAL: WEIGHT: g

LOCATION:

REV:

BATCH NR:

REKV.NR / ORDRE NR:

ORDRE DATO:

LEV.DATO:

*Jefa Rudder*  
SYSTEMS

JEFA MARINE A/S  
NIMBUSVEJ 2  
2670 GREVE. DENMARK  
Tlf: +45 4615 5210 & Fax: +45 46155208  
Email: info@jefa.com www.jefa.com

: /